

PowerBoss® SW/70

OPERATION & MAINTENANCE MANUAL

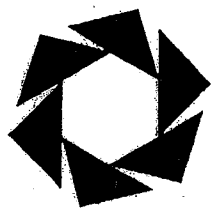
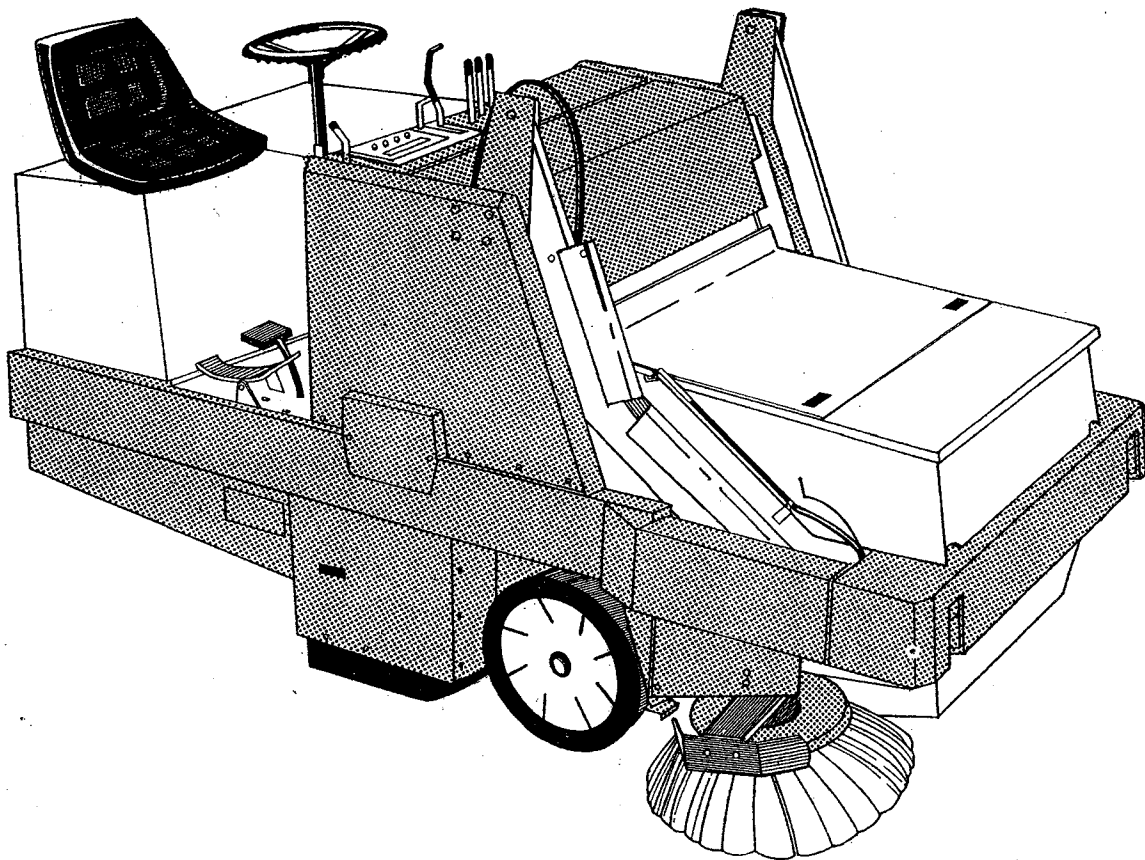

AAR Brooks & Perkins

TABLE OF CONTENTS
Introduction

Introducing the SW/70 PowerBoss™ Sweeper..... A-1
Special Features..... A-2

SPECIAL FEATURES

You will enjoy all of the following features on your PowerBoss™ sweeper:

- rugged one-piece unitized frame
- reliable hydraulic drive with easy-to-service components
- high and effective direct-throw sweeping
- high capacity hoppers with dust control
- rear wheel drive/steering for exceptional maneuverability
- four cylinder, liquid-cooled engine
- transverse mid-engine design, providing stability and accessibility for maintenance
- floating brooms for uneven surfaces

TABLE OF CONTENTS
Safety

Safety Symbols B-1

Safety Decals B-2

Basic PowerBoss™ Safety B-6

SAFETY SYMBOLS

Five symbols are used throughout this manual to emphasize various levels of safety information. These symbols and the meaning of each are listed below.



DANGER

DANGER: To warn of immediate hazards which will result in severe personal injury or death.



WARNING

WARNING: To warn of hazards or unsafe practices which could result in severe personal injury or death.



CAUTION

CAUTION: To warn of hazards or unsafe practices which could result in minor personal injury.

ATTENTION!

ATTENTION! To warn of practices which could result in extensive equipment damage.

NOTE

NOTE: To direct your attention to important equipment information or special instructions for preventing damage to equipment.

Symbols at the top of the list are the strongest warnings. However, all symbols represent important information which should be observed to protect you and others from harm and injury, and to prevent damage to equipment.

SAFETY DECALS

Decals directly attached to various parts of the sweeper are highly visible safety reminders which should be read and observed. Make sure the decals are replaced if they become illegible or damaged. The decal below is located in the drive compartment. Other decals on your machine appear on the next page.



CAUTION

For Your Safety And Safety Of Others:

1. **DO NOT Operate Machine:**
Unless Operation Manual Is Read And Understood
Unless Authorized And Trained.
In Areas With Flammable Or Explosive Conditions.
Without Adequate Ventilation.
2. Do Not Use Flammable Cleaning Materials.
3. Inspect Vehicle For Fuel Leakage.
4. Drive Slowly On Inclines And Slippery Surfaces.
5. Do Not Power Dump Hopper Unless Vehicle Is On A Level Surface.
6. Before Leaving Vehicle: Lock Parking Brake, Stop Engine, And Remove Key.

Located at the impeller.

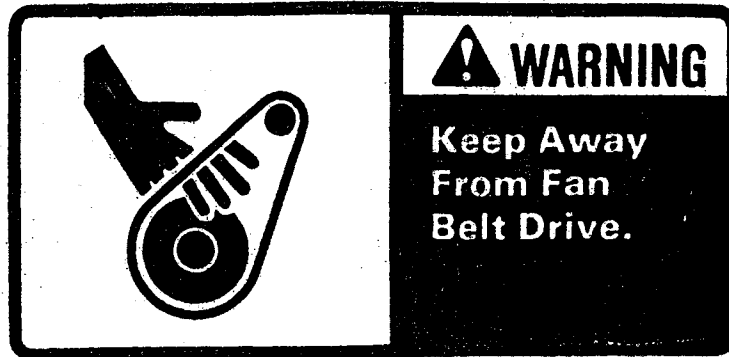

Located at the impeller.

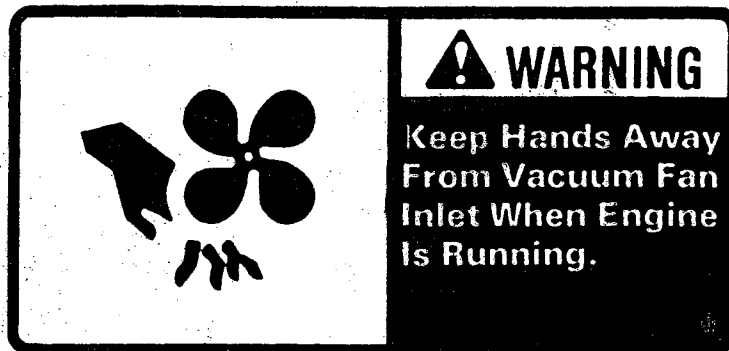

Located on the high dump hopper.

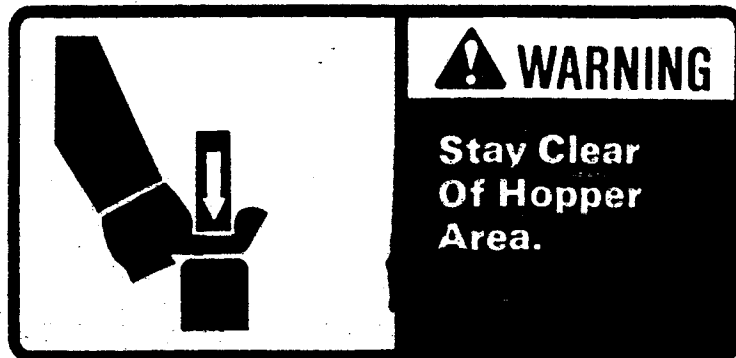

Located on the high dump hopper.

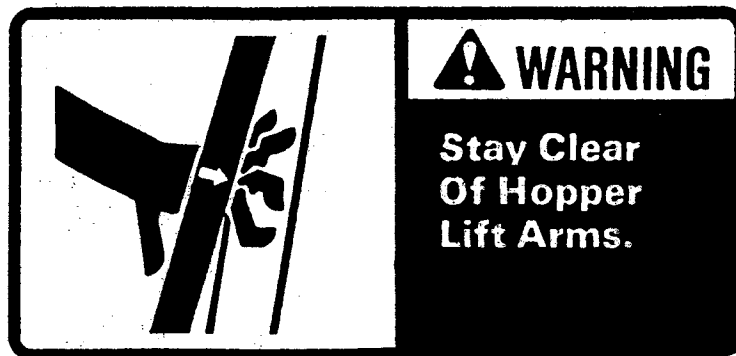

Located on the shroud of the radiator.

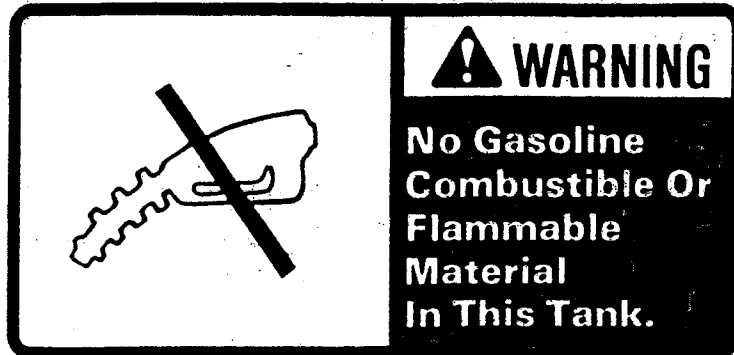

BASIC POWERBOSS™ SAFETY

PowerBoss™ sweepers should never be operated unless: 1. the operator is trained and authorized to operate the equipment and, 2. the equipment is free of malfunctions. Malfunctioning equipment should be removed from service.



DANGER

1. Keep cigarettes, matches, and all other flame sources away from the sweeper. Gasoline is highly flammable. Lead acid batteries are equally dangerous due to the highly explosive hydrogen gas they emit.



WARNING

1. Before starting the engine, make sure that:
 - The latch for rear cover is locked (located at floor board of operator compartment).
 - You are securely seated in the operator's seat.
 - The parking brake is locked.
 - The directional control pedal is in neutral.
 - The throttle is in idle.
 - Hydraulic controls are in OFF position.
2. During operation:
 - Keep your hands and body clear of moving parts, especially when the hopper or lift arms are partially or fully raised.
 - Make sure others in the area stay clear of the equipment and moving parts.
 - Never attempt to dump debris from a dock or mezzanine. Dump from ground level only.
3. When leaving the sweeper unattended:
 - Place the controls in OFF position.
 - Set the parking brake.
 - Shut off the engine.

4. During cleaning and maintenance:

- Always stop the engine and set the parking brake before servicing.
- Do not attempt any impeller adjustment unless you have shut off the engine. Never place your hands near the intake hoses or inlet when the engine is running.
- Always engage the safety arm before getting under the hopper. Do not rely on the hydraulic cylinder to keep the hopper raised.

5. When servicing or repairing the fuel system:

- Work in a properly ventilated area, do not smoke, or allow an open flame near the fuel system.
- Never bypass safety components unless you are testing them.

6. Replace any defective safety components before operating the sweeper.

7. Do not operate a LPG powered sweeper when any component in the fuel system is malfunctioning or leaking.



CAUTION

1. Do not drive with the hopper in the raised position except the few feet necessary to position the hopper over the dumpster or receptacle. Driving with the hopper raised reduces visibility and creates conditions for striking overhead objects, throwing the machine off balance, and other hazards.
2. Travel slowly on grades.
3. Place a block or chock behind the wheels when parking on inclines.
4. Use special care when traveling on wet surfaces.
5. Observe all proper procedures for operation and maintenance of the sweeper, as outlined in this manual.
6. Remain alert at all times to people and equipment in and around your area of operation.

ATTENTION!

1. Do not tow or push the machine a distance of more than .5 miles or faster than one mile per hour. Exceeding these restrictions may cause damage to the hydraulic system. If towing exceeds the above restrictions, the rear wheel must be raised or supported by a dolly.

TABLE OF CONTENTS
Specifications

SW/70C-1

SPECIFICATIONS SW 70

FRAME, WEIGHT, DIMENSIONS

Frame	Unitized construction, 3/16" steel plate, reinforced at stress points
Net Weight	2250 lb.
Shipping Weight	2650 lb.
Length	98.37"
Width	54.12"
Height	57.0"
Height with Overhead Guard	87.0"
Height with Cab	83.50"

ENGINE, BATTERY

Battery	Electric start 12 volt, maintenance free
Gasoline	Liquid cooled, transverse mid-engine design

STEERING, BRAKES, PERFORMANCE

Steering	Drive and steering through rear wheel
Parking Brakes	External contact brakes on the two front wheels
Max. Forward Speed	8 mph
Min. Isle Width Required for U-Turn	108"

FLUID CAPACITIES

Fuel Tank	8 gal.
Radiator	
Total Coolant System	3½ qt.
Hydraulic Fluid Reservoir	6 gal.

CLEANING COVERAGE, TANK AND HOPPER CAPACITIES

Vacuum System	High speed 9" impeller One fully enclosed positive sealed panel filter 50 sq. ft. of filtering area One electric filter shaker
Total Sweep Path	
Main Broom Path	36"
Sweep Coverage	158,400 sq. ft. per hour with 6" overlap (based on 54" path at 7.5 mph with 6" overlap)
Hopper Capacity	1,000 lb., 14 cu. ft.

CLEANING COMPONENTS

Main Broom	Cylindrical, one-piece, disposable, 14" diameter x 36" long
Side Broom	Rotary, one-piece, disposable, diameter

HYDRAULICS

Wheel Motor	Char-Lynn 2000 Series 18.7 cu. in. per rev. displacement High torque, low speed Protected by 3000 psi relief valves
Broom Motors	Char-Lynn A Series Gerotor, high torque, low speed
Propulsion Pump	Cessna Variable Displacement Piston Pump 1.24 cu. in. per rev. displacement Protected by 3000 psi relief valve
Accessories Pump	Cessna gear pump .84 cu. in. per rev. displacement Protected by 2200 psi relief valve
Directional Control Valve	Cessna
System Filter	Parker 10 micron spin-on
Heat Exchanger	One-piece tubular coil

TABLE OF CONTENTS
Component Descriptions

The Engine.....	D-1
The Air Intake System	D-1
The Electrical System.....	D-2
The Fuel System	D-3
The Coolant System	D-3
The Lubrication System	D-3
The Hydraulics Systems.....	D-3
The Vacuum System.....	D-4
Sweep Components.....	D-4
Hoppers.....	D-5
Steering, Brakes, and Tires	D-5

THE ENGINE

Engines are:

- 3 cylinder
- liquid cooled,
- electrically started, and
- transverse, mid-engine designed.

Additional Information

For additional detailed information about the engine on your sweeper, refer to the vendor's engine manual furnished with this manual. In it you will find information on the following components:

- carburetor
- alternator
- governor
- fuel pump
- starter
- points and plugs
- fan belt
- water pump
- distributor

THE AIR INTAKE SYSTEM

Air Intake System

Engines are equipped with a dry cartridge type air filter with a rubber dust cup in the housing. The filters are accessible for easy removal and cleaning.

THE ELECTRICAL SYSTEM

Battery

The battery is a 12-volt, 325 cold cranking amp battery.

Circuit Breakers

The four circuit breakers which protect the circuits are located on the instrument control panel. Below is a chart of the circuits they protect.

Circuits

As viewed left to right from the operator's seat:

1. 15 AMP - Engine Oil Pressure and Coolant Temperature Lights, Hour Meter, Anti-Dieseling Solenoid, and the Ignition Coil
 2. 15 AMP - Voltage Regulator
 3. 15 AMP - Shaker Motors and Horn
 4. 15 AMP - Headlights, Taillights and Options
-

Instruments

Gauge and indicator lights include an hour meter, oil pressure indicator light, and water temperature indicator light. For descriptions of these basic instruments and various accessory instruments, refer to the controls section of this manual.

THE FUEL SYSTEM

Engines receive fuel from an 8-gallon capacity tank. Fuel is received through inline, disposable filters. Fuel system characteristics are listed below.

- fuel tank
- fuel filter
- mechanical fuel pump
- carburetor
- manually operated carburetor choke

THE COOLANT SYSTEM

Engine coolant is stored in a radiator and circulates through hoses and engine block which bring the total system capacity to 3½ quarts.

A spring-loaded valve in the radiator pressure cap, designed to open at 14 psi, closes the outlet to the overflow pipe.

THE LUBRICATION SYSTEM

Grease fittings supply lubrication to:

- impeller bearing housing
- steering gear box
- steering link arm
- steering fork assembly
- pillow blocks supporting dump arms

For detailed information on lubrication requirements and the lubrication points and grease fittings, refer to the Maintenance section of this manual.

THE HYDRAULICS SYSTEM

Hydraulic fluid is pumped from an eight-gallon capacity reservoir. The fluid passes through a 100 mesh suction strainer into supply lines which circulate fluid through two systems: the propulsion system and the accessory system. Fluid returns through a heat exchanger and a filter.

Propelling System

The major component of the propelling system is a variable displacement piston pump protected by relief valves. The pump sends fluid to drive the wheel motor which controls the forward and reverse speed of the machine, as well as dynamic breaking.

Accessories System

The major component of the accessories system is a gear pump. The gear pump, protected by a relief valve, sends fluid through a control valve to raise and lower hopper, to rotate hopper, and to drive brooms.

Brooms are driven by gerotor-type high torque, low speed motors. Hopper is raised, lowered, and rotated by hydraulic cylinders.

THE VACUUM SYSTEM

- Impeller and Belts** The vacuum system operates from a high speed 9" impeller, belt-driven off the engine.
- Filter and Shaker** SW/70 models have one fully enclosed, positive sealed, quick-change filter providing 50 sq. ft. of filtering area and one electric shaker for cleaning the filter.

SWEEP COMPONENTS

- Main Broom** The main broom has the following features:
- one-piece, cylindrical, and disposable
 - runs at constant RPM
 - can be changed in less than five minutes
 - is raised and lowered from operator compartment
 - floats for uneven surfaces
 - adjusts for pressure and wear
- Side Broom** A rotary one-piece disposable side broom is bumper protected, and adjustable for angle, pressure, and wear.
- Skirts** Skirts on the bottom of each broom door and at the back of the broom chamber help contain the dust inside the sweeping and vacuuming compartment.
- Capabilities** Sweep paths and coverages are listed by model in the Specifications section of this manual.

HOPPERS

SW/70hoppers are constructed of 12 GA steel and come with powered multi-level high dump.

All machines are equipped with a frame seal and side seals to contain dust and fine debris within the hopper.

Rotary Trash Relocator

The rotary trash relocator (RTR) increases the debris-holding capacity of the hopper, extending the sweeping time before dumping. By rotating the hopper about halfway through the dump rotation, the debris at the lip of the hopper moves to the front wall, leaving the entrance area clear to receive and hold more debris.

STEERING, BRAKES, AND TIRES

Steering

PowerBoss™ sweepers are designed with standard cam and lever steering through the rear wheel.

Brakes

The PowerBoss™ SW/70s are equipped with a parking/emergency brake, mechanically operated by a cable which connects external contact brakes on the two front wheels.

Tires

PowerBoss™ sweepers use an interchangeable, two-piece, bolt-together cast rim for mounting the solid tires used in the rear of the machine. The two front tires are one-piece cast rims with press-on rubber tires. For more detailed information related to dimensions refer to the Specifications and Maintenance sections of this manual.

TABLE OF CONTENTS
Operation

Basic Operating Controls.....	E-1
Sweeping Controls.....	E-5
Debris Hopper Dump Controls.....	E-6
Operating Procedures	E-7
Pre-Operation Checks	E-7
Starting.....	E-7
Slowing and Stopping.....	E-7
Operating on Grades.....	E-7
Sweeping	E-8
Emptying the Hopper.....	E-8
Relocating the Trash in the Hopper.....	E-9
Transporting the Machine.....	E-10

BASIC OPERATING CONTROLS*

- IGNITION SWITCH** The four position ignition switch is used to start the engine. Turn the key to START position, then release.
- HORN** The horn is activated by pressing the horn button located on the right side of the instrument panel.
- FUEL LEVEL GAUGE (Optional)** The fuel level gauge indicates the amount of fuel remaining in the tank.
- HOUR METER** The hour meter records the number of hours the machine has been operated, providing a helpful guide for performing routine maintenance tasks.
- ENGINE CHOKE KNOB** The choke knob on gasoline-powered machines is connected to a cable which controls the engine choke.
- Pull the knob out for aid in colding starting the engine.
 - Push the knob in after the engine starts.
- ENGINE OIL PRESSURE INDICATING LIGHT** The engine oil pressure light illuminates if pressure drops below 7 psi. The light indicates problems which may result in damage to the machine.
- ENGINE COOLANT TEMPERATURE INDICATING LIGHT** The engine coolant temperature light indicates the engine is overheating. If light is on, engine should be shut down and given further attention.
- THROTTLE** The throttle adjusts the engine speed from idle to one of the sweeping speeds.
- The throttle should be in the IDLE position (turtle picture) when starting the engine and immediately before shutdown.
 - Low speed (rabbit picture) position should be used during normal operation to insure proper broom speed and dust control.
 - Fast speed (tornado picture) should be used when sweeping light debris.

* Refer to the control drawing on the following page.

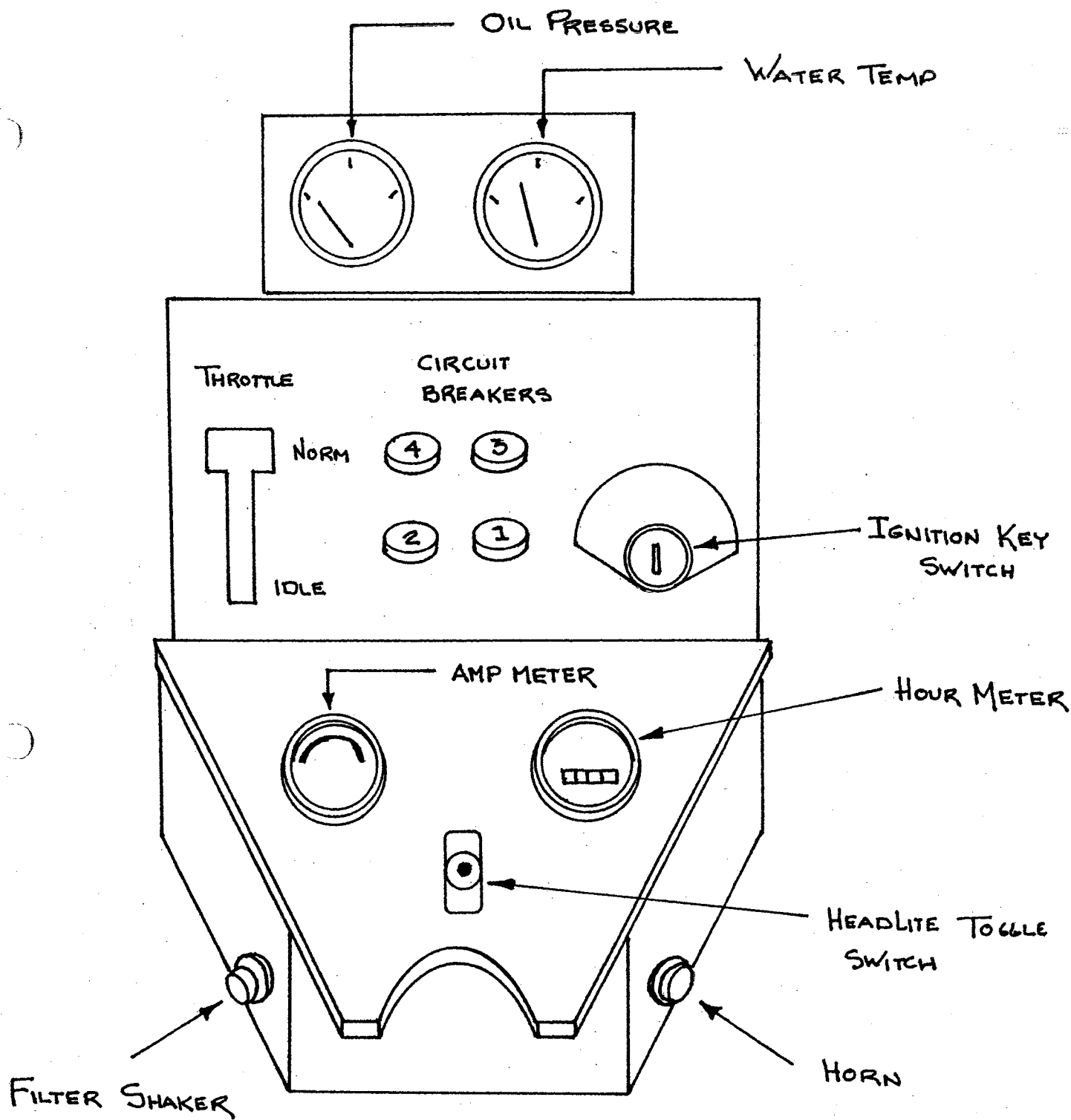

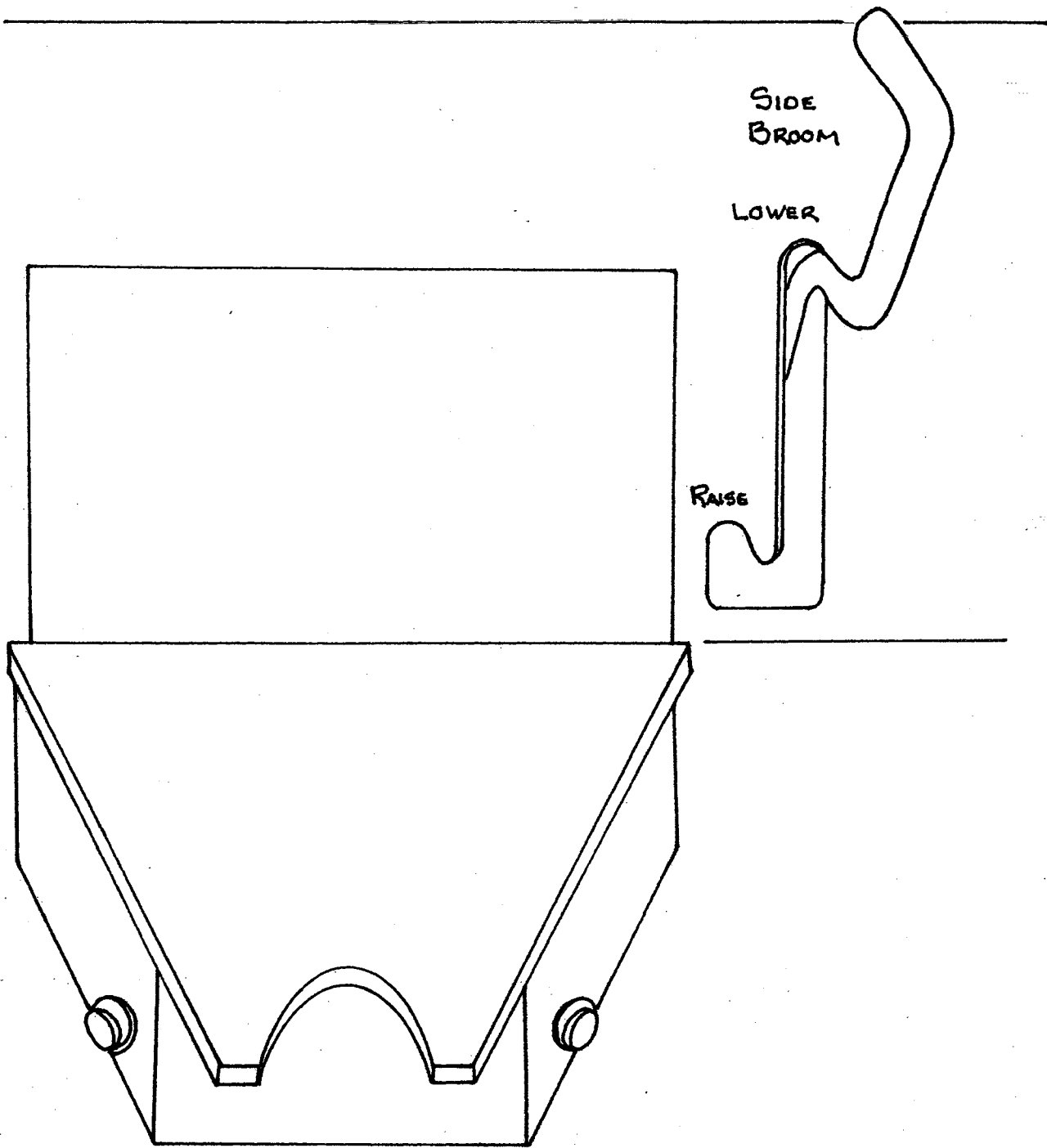

DIRECTIONAL CONTROL PEDAL

The directional control pedal controls the speed and direction of the machine. It is also used for slowing the machine or stopping.

- To propel the machine forward, apply pressure to the front of the pedal, increasing pressure to increase speed.
- To propel the machine backward, apply pressure to the rear of the pedal.
- To slow or stop the machine, move foot pedal into neutral.
- For quick stops or emergency stops move foot pedal past neutral into opposite position.

The sweeper is equipped with a speed limiter, a stop under the pedal which can be raised to reduce maximum speed.

PARKING/EMER- GENCY BRAKE

The mechanical contact brakes on the two front wheels are used primary for parking the machine and are operated by the brake pedal. Chock wheels if machine is parked on an incline.

NOTE: The directional control pedal is used to slow and stop during normal operation. For emergency stopping, such as rapid stopping or stopping on inclines, use the emergency brake.

- To engage the brakes, press down on the pedal.
- To lock the parking brake, press down on the pedal and apply pressure to the pedal lock which is immediately in front of the brake pedal pad.
- To release the parking brake, press down on the brake pedal pad until the pedal lock springs free.

Sweeping Controls

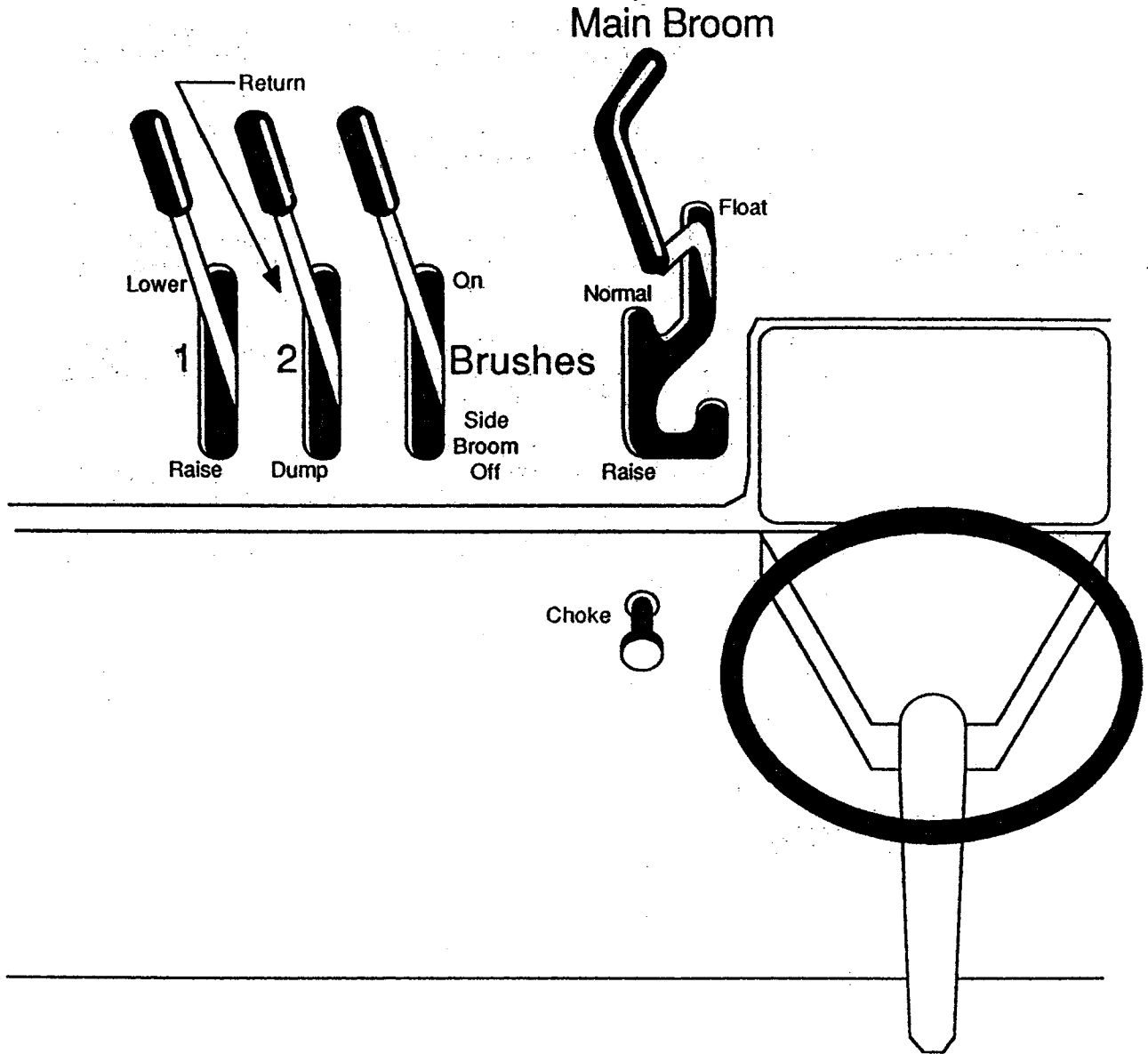

SWEEPING CONTROLS

BROOM CONTROL LEVER

The broom control lever to the left of the main broom handle activates the brooms.

NOTE: Even though brooms are rotating each can be lowered independently.

When sweeping:

- To activate the main and side brooms, push this lever to the ON position.
- To activate the main broom only, pull this lever to the SIDE BROOM OFF position.
- The center (straight up) position is the OFF position.

MAIN BROOM HANDLE

The main broom handle to the immediate left of the instrument panel raises and lowers the main broom.

- For normal sweeping, position the handle at NORMAL on the handle slot.
- For extremely uneven floors, position the handle at FLOAT on the handle slot.

NOTE: Extensive use of the float position reduces broom life.

- When not sweeping, position and lock the handle at RAISE on the handle slot.

SIDE BROOM HANDLE

The side broom handle to the right of the instrument panel raises and lowers the side broom.

- When not sweeping, the side broom should remain in the raised position.
- To lower the broom, position the handle at LOWER in the handle slot.
- To raise the broom, position the handle at RAISE in the handle slot.

DEBRIS HOPPER DUMP CONTROLS

HOPPER FILTER SHAKER BUTTON

This button is used to activate the filter shaker prior to dumping or as needed for cleaning the dust control filter. Hold the button in approximately 15 - 20 seconds, or as long as necessary to clean the filter.

HIGH DUMP CONTROLS

The two far left levers on the front control panel are used to raise the hopper to any height up to 60" and dump it.

NOTE: Levers are spring loaded to a center off position.

- To raise the hopper, pull back Lever 1 to the RAISE position and hold until the hopper raises to the proper height for the dumpster or container.
- To empty debris, pull back Lever 2 to the DUMP position to rotate the hopper forward and empty the debris.
- To rotate the hopper back, push Lever 2 forward to the RETURN position until the hopper rotates and stops.
- To lower the hopper, push Lever 1 forward to the LOWER position until the hopper stops.

ROTARY TRASH RELOCATOR (RTR)

Rotary Trash Relocator (RTR) is a standard feature on high-dump models. Its purpose is to increase the holding capacity of the debris hopper to make dumping the hopper necessary less frequently.

OPERATING PROCEDURES

PRE-OPERATION CHECKS

Prior to starting the engine, check the following:

1. Engine oil level
2. Engine coolant level
3. Fuel level
4. Hydraulic fluid level
5. Brakes, steering, and directional controls
6. The floor beneath the machine for leak spots

Fluid levels should be correct. Brakes, steering, and directional controls should be functioning properly. Hoses, lines, and tanks should be free of damage and leaks.

STARTING



WARNING: Before cranking the engine, seat yourself in the operator's seat and make sure the parking brake is locked.

1. Make sure the directional control pedal is in neutral position.
2. Make sure the throttle is in idle position.
3. Turn the key to START position, then release. If the engine is cold, pull out the choke knob, turn the key to START, then release. When the engine is running smoothly, push in the choke knob.

NOTE: If the engine fails to start, do not continue cranking for over ten seconds. Allow the starter motor to cool between attempts.

4. Allow the engine to warm up approximately two minutes.
5. Move the throttle from IDLE to RUN.
6. Unlock the parking brake.
7. Move the machine forward or backward as follows:
 - Forward: Apply pressure to the front of the directional control pedal, increasing pressure to increase speed.
 - Reverse: Apply pressure to the rear of the pedal, increasing pressure to increase speed.

SLOWING AND STOPPING

1. Allow the directional control pedal to move into neutral. The machine will slow and coast to a stop.

OPERATING ON GRADES

1. Always travel slowly.
2. Exercise extreme caution when traveling across or turning on grades.

SWEEPING

1. Lower the brooms.
 - Lower the main broom by positioning the main broom handle at **NORMAL** on the handle slot.
 - When sweeping extremely uneven floors, position the main broom handle at **FLOAT** on the handle slot.
 - Lower the side broom by positioning the side broom handle at **LOWER** in the handle slot.
2. Activate the broom motors.
 - Activate the main broom motor by pulling the broom and brush control lever to the **SIDE BROOM OFF** position.
 - Activate both main and side broom motors by pushing the broom and brush control lever to the **ON** position.
3. Drive the machine over the area to be swept.

EMPTYING THE HOPPER

1. Drive the machine to the dumping area.
2. Use the directional control pedal to position the machine so that the space between the machine and the container or dumpster is adequate to raise the hopper.

NOTE: Broom control lever must be in center off position.

3. Reduce the engine speed.
4. Pull back Lever 1 to **RAISE** position and hold until the bottom of the hopper is high enough to clear the top of the container.



WARNING: Never place your hands or other body parts near the lift arms when the hopper is operating.

5. Use the directional control pedal to slowly and carefully move the machine forward until the hopper is properly positioned to dump debris into the container.



CAUTION: It is unsafe to travel an extended distance with the hopper raised. Travel only the distance necessary to position the hopper.

6. At this point, shake filters for 20 - 30 seconds. Pull back Lever 2 to **DUMP** position to rotate the hopper forward and empty the debris.
7. After hopper empties, push Lever 2 forward to **RETURN** position until the hopper rotates and stops.
8. Slowly back machine away from dumpster approximately 5 ft.
9. Push Lever 1 forward to the **LOWER** position until the hopper stops.

**RELOCATING THE
TRASH IN THE
HOPPER**
(RTR Feature)

1. Use the directional control pedal to stop the machine on a level surface.
2. Move the throttle to IDLE position.
3. Pull back Lever 1 to the RAISE position and hold until hopper opening comes into view, then release. (This is sufficient clearance to rotate hopper.)



WARNING: Make sure no one is in the area under or around the hopper.

4. Pull back Lever 2 to DUMP position and hold until the hopper rotates 90° (bumper is on bottom, pointed toward floor), then release.

NOTE: This rotates the hopper, causing debris to move from the rear entrance to the front wall of the hopper. Rotating beyond this point will cause debris to be dumped from the hopper.

5. Push Lever 2 forward to RETURN position until the hopper rotates back and stops.
6. Push Lever 1 forward to the LOWER position until the hopper returns to the normal operating position.
7. Move the throttle back to RUN and resume sweeping.

TRANSPORTING THE MACHINE

Loading

1. Position the machine on the transport vehicle or trailer and apply the parking brake.
2. Tie the machine down using the tie down holes in the frame behind both front wheels and eye bolts located at rear of frame.

NOTE: Attach the tie downs to the frame only.

Pushing

1. Push the machine from the front or rear using bumpers only.

ATTENTION! Do not tow or push the machine a distance of more than .5 miles or faster than one mile per hour. Exceeding these restrictions may cause damage to the hydraulic system. If towing exceeds the above restrictions, the rear wheel must be raised or supported by a dolly.

TABLE OF CONTENTS
Maintenance

Introduction.....	F-1
Preventive Maintenance Chart.....	F-2
Engine.....	F-6
Air Intake and Exhaust Systems.....	F-7
Air Filter Removal.....	F-7
Air Filter Cleaning.....	F-8
Air Filter Inspection.....	F-8
Air Filter Installation.....	F-9
Battery Cleaning.....	F-11
Battery Replacement.....	F-12
Fuel System.....	F-13
Coolant System.....	F-14
Blowing Out Radiator Fins.....	F-14
Reverse Flow Flushing.....	F-14
Lubrication.....	F-16
Changing Engine Oil.....	F-17
Lubrication Points.....	F-18
Lubrication Chart.....	F-19
Hydraulics System.....	F-22
Filling the Fluid Reservoir.....	F-22
Maintaining Cooling Coil Efficiency.....	F-23
Changing the Hydraulic Fluid.....	F-23
Changing the Hydraulic Fluid Filter.....	F-24
Adjusting the Directional Control Return Spring.....	F-24
Adjusting Machine Speed.....	F-26

Hydraulics System (cont.)

Hydraulic Schematic.....	F-27
SW/70	F-28
Vacuum System	F-29
Belt Tensioning.....	F-29
Pulley Realignment.....	F-30
Lubrication of Impeller Bearing Housing	F-31
Sweep Components.....	F-32
Broom Door Flap Inspection	F-33
Broom Door Flap Replacement and Adjustment.....	F-33
Main Broom Adjustment Test.....	F-34
Main Broom Adjustment.....	F-35
Main Broom Taper Adjustment.....	F-36
Side Broom Adjustment Inspection.....	F-37
Side Broom Angle Adjustment	F-38
Side Broom Lift Cable Adjustment	F-39
Main Broom Replacement	F-39
Side Broom Replacement	F-41
Hoppers.....	F-42
Hopper Removal and Replacement.....	F-42
Filter Removal.....	F-43
Filter Cleaning	F-44
Filter Replacement.....	F-44
Hopper Floor Clearance and Dump Adjustments.....	F-45
Hopper Vacuum Gasket Mount Adjustment	F-46
Hopper Flap Replacement.....	F-46
Hopper/Frame Seal Replacement.....	F-47

5

Steering.....	F-48
Parking/Emergency Brake.....	F-49
Parking Brake Adjustment.....	F-49
Tires.....	F-50
Changing Rear Solid Tires.....	F-50
Changing Front Press-On Tires.....	F-50
Miscellaneous Adjustments.....	F-51

00

00-

INTRODUCTION

Regular maintenance on your sweeper results in better cleaning, faster cleaning, and a prolonged service life for the equipment and components. This section contains the following information to help you give your sweeper the maintenance attention it requires:

- A Preventive Maintenance Chart
- Service Instructions for Required Maintenance Tasks

Because it is extremely important to your safety, you will see the following **WARNING** repeated throughout this section:



WARNING: Never attempt to perform any service on the equipment or components until the engine is OFF, the parking brake is LOCKED, and the wheels are CHOCKED.

PREVENTIVE MAINTENANCE CHART

FREQUENCY (IN HOURS)					SERVICE (BY MAINTENANCE AREA)
Daily	50	100	200	500	
			X		<p>ENGINE</p> <p>Pressure wash engine.</p> <p>For additional maintenance requirements, refer to the engine manual furnished with this manual.</p> <p>AIR INTAKE AND EXHAUST SYSTEMS</p> <p>Empty rubber dust cup of air filter element.</p> <p>Clean air filter. NOTE: Clean more often in dusty conditions.</p> <p>Replace air filter.</p> <p>ELECTRICAL SYSTEM</p> <p>Check electrolyte level in battery cells and fill as needed.</p> <p>Clean battery top.</p> <p>COOLANT SYSTEM</p> <p>Check coolant level and fill as needed.</p> <p>Inspect radiator fins and clean as needed.</p> <p>Blow out radiator fins.</p> <p>Drain and flush coolant system.</p>
X		X			
			X		
		X			
			X		
X					
	X				
	X				
				X	

PREVENTIVE MAINTENANCE CHART

FREQUENCY (IN HOURS)					SERVICE (BY MAINTENANCE AREA)
Daily	50	100	200	500	
		X			<p>HYDRAULIC FLUID</p> <p>Check hydraulic reservoir gauge and fill as needed.</p> <p>Blow off or pressure wash cooling coil.</p> <p>Replace hydraulic fluid and filter.</p> <p>Check functioning of directional control pedal and adjust as needed.</p> <p>Clean hydraulic fluid strainer in reservoir.</p>
X				X	
X				X	
	X				<p>SWEEPING COMPONENTS</p> <p>Inspect brooms for wear and remove strings and debris from bristles and drive assembly.</p> <p>Inspect broom skirts for wear and adjust or replace as needed.</p> <p>Rotate main broom end-to-end.</p> <p>Perform main broom adjustment test and adjust as needed.</p> <p>Inspect the side broom for wear; adjust as needed.</p> <p>Check main and side brooms; replace as needed.</p>
	X				
	X				
	X				
X					
X					

PREVENTIVE MAINTENANCE CHART

FREQUENCY (IN HOURS)					SERVICE (BY MAINTENANCE AREA)
Daily	50	100	200	500	
					HOPPER
X					Check hopper filter and clean or replace as needed.
	X				Check hopper clearance from floor and adjust as needed.
X					Inspect the hopper flaps for wear or damage and replace as needed.
		X			Inspect hopper side and frame seals for wear or damage. Adjust or replace as needed.
				X	Lubricate the pillow blocks supporting the dump mechanism.
					STEERING
				X	Lubricate steering gear box.
				X	Lubricate steering link arm.
				X	Lubricate steering fork assembly.
				X	Check steering gear box for wear and adjust as needed.
					PARKING BRAKE
X					Check for proper functioning and adjust as needed.

PREVENTIVE MAINTENANCE CHART

FREQUENCY (IN HOURS)					SERVICE (BY MAINTENANCE AREA)
Daily	50	100	200	500	
X					<p>TIRES</p> <p>Visually inspect for wear and damage. Repair or replace as needed.</p>
			X		<p>MISCELLANEOUS</p> <p>Inspect latches and hinges. Tighten and lubricate as needed.</p> <p>Check anti-static drag chain on rear wall of broom chamber for damage or excessive wear. Replace as needed.</p>
				X	<p>Check side broom lift cable, and brake cable for wear.</p>
	X	X			<p>IMPELLER</p> <p>Lubricate.</p> <p>Check belt tension and alignment.</p>

ENGINE

Maintenance requirements and service instructions for your sweeper engine are outlined in the following parts of this Maintenance section:

- Air Intake and Exhaust Systems
- Electrical System
- Fuel System
- Coolant System
- Lubrication System

All basic maintenance tasks are listed with their recommended frequencies on the Preventive Maintenance Chart in this manual. Important additional maintenance requirements and instructions are explained in the engine manual which comes with your machine.



WARNING:

Never attempt to perform any service on the equipment or components until the engine is OFF, the parking brake is LOCKED, and the wheels are CHOCKED.

AIR INTAKE AND EXHAUST SYSTEMS

To keep the air intake and exhaust systems operating efficiently:

- Empty the rubber dust cup of the air filter element daily.
 - Clean the engine air filter every 50 hours of operation. **NOTE:** Clean more frequently in dusty conditions.
 - Replace the air filter every 500 hours of operation or as required.
-

SERVICE INSTRUCTIONS



WARNING: Never attempt to perform any service on the equipment or components until the engine is OFF, the parking brake is LOCKED, and the wheels are CHOCKED.

AIR FILTER REMOVAL

1. Turn off the engine and set the parking brake.
2. Lift the engine cover.

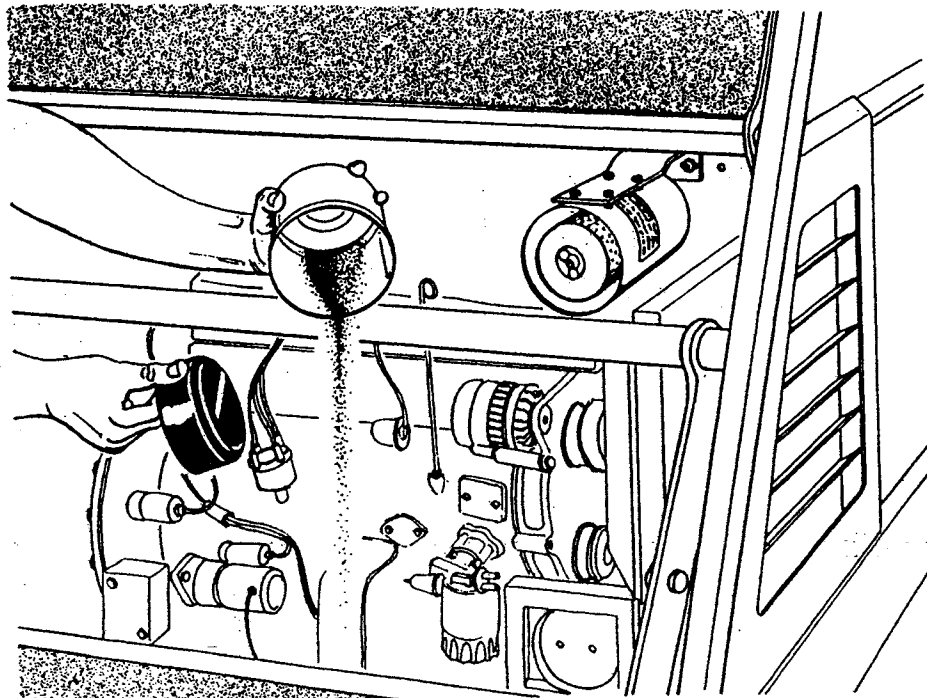

3. Locate the air filter and unscrew the ring clamp.
4. Remove the dust cup.
5. Pull the rubber plug out of the dust cup and empty the contents.
6. Unscrew the wing nut.
7. Pull the air filter out of its housing.

AIR FILTER CLEANING

1. Once you have removed the air filter, empty the dust cup and clean the interior of the air filter housing.
2. Use an air hose to blow out the air filter. Air pressure should be 100 psi or less.

AIR FILTER INSPECTION

1. After you clean the air filter, check it for holes by passing a light bulb inside it. If you detect so much as a pin-hole, the filter should be replaced.

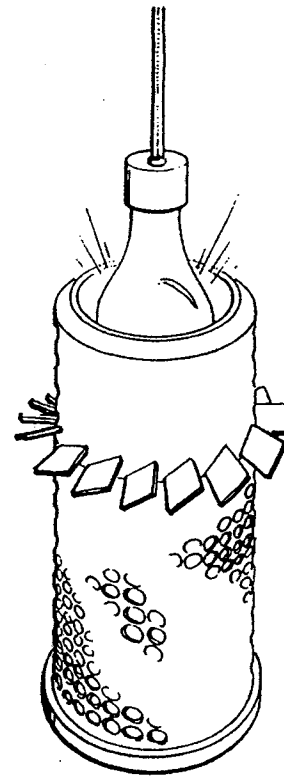

AIR FILTER INSTALLATION

1. Wipe out the air cleaner housing with a damp cloth. Be sure all dirt is removed.
2. Install the cleaned or replacement filters so that fins are at the far end of the housing. Be careful not to damage the fins.
3. Replace the wing nut and tighten it.
4. Replace the rubber plug in the dust cap.
5. Replace dust cup being sure embossed word "top" on cup is positioned correctly (up).
6. Tighten the ring clamp.
7. Check condition of intake hoses and clamps.
8. Close the engine cover.

ELECTRICAL SYSTEM

To keep the electrical system in good condition, the following maintenance is required:

- Check the electrolyte level in each of the battery cells every 100 hours of operation and replenish as needed.
 - Clean the battery posts and cover after 200 hours of operation.
 - Use the color-coded wiring harness and the electrical schematic provided in this section to assist you with troubleshooting, testing, and diagnosis.
-

SERVICE INSTRUCTIONS



WARNING: Never attempt to perform any service on the equipment or components until the engine is OFF, the parking brake is LOCKED, and the wheels are CHOCKED.

BATTERY CLEANING

1. Combine baking soda and water in a strong solution.

NOTE: ON SW 70
BATTERY LOCATED
IN REAR CLIP

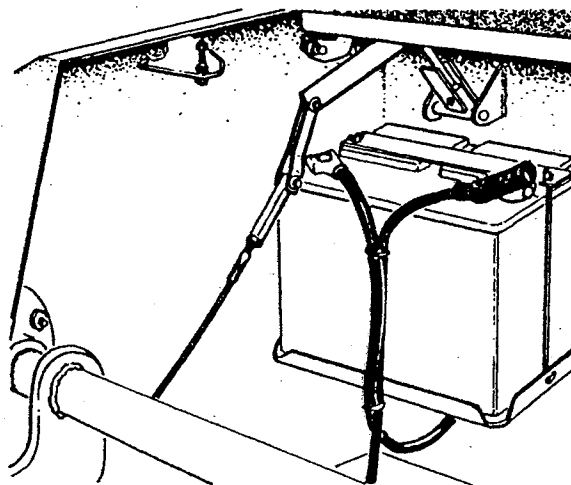

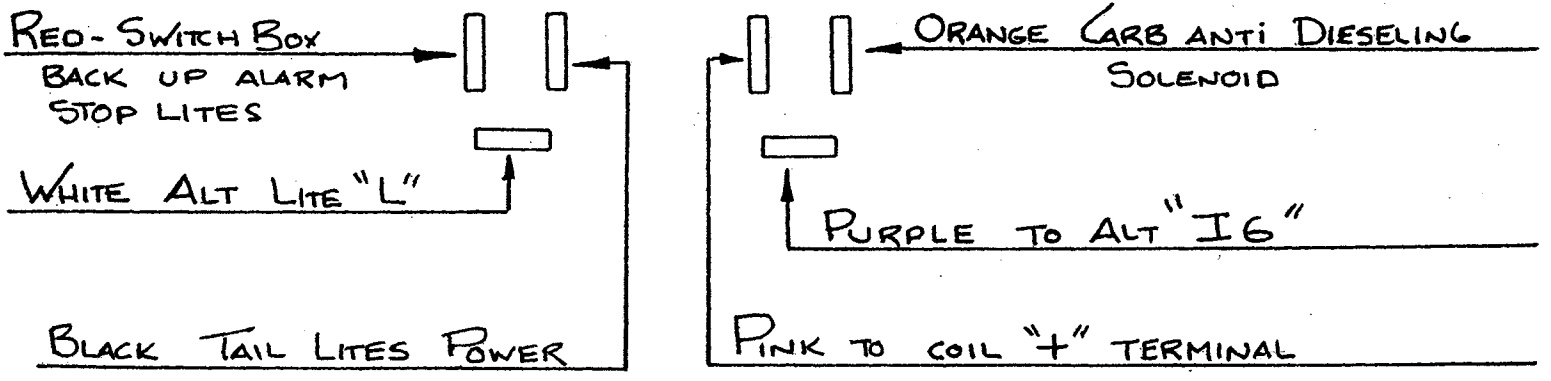
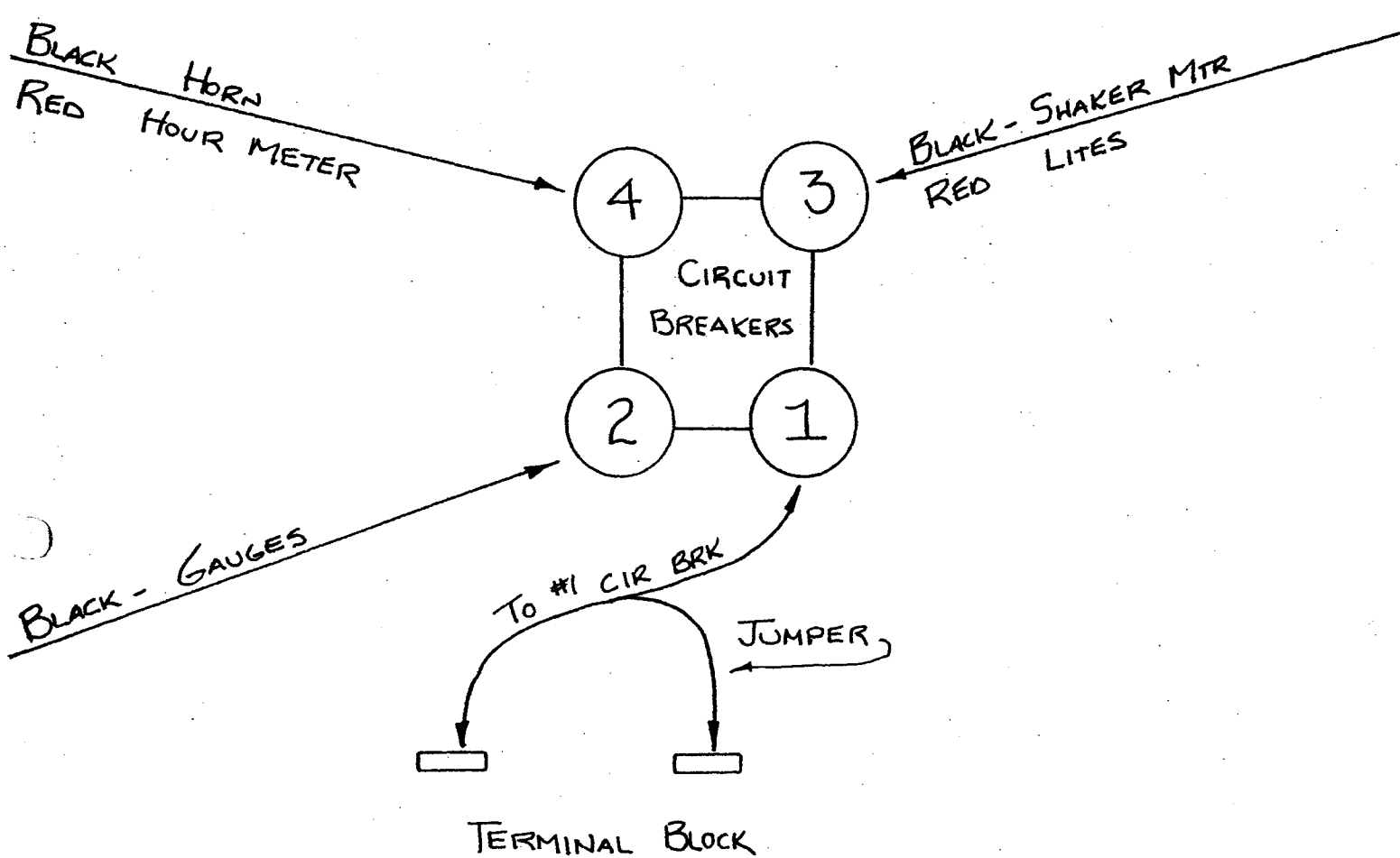
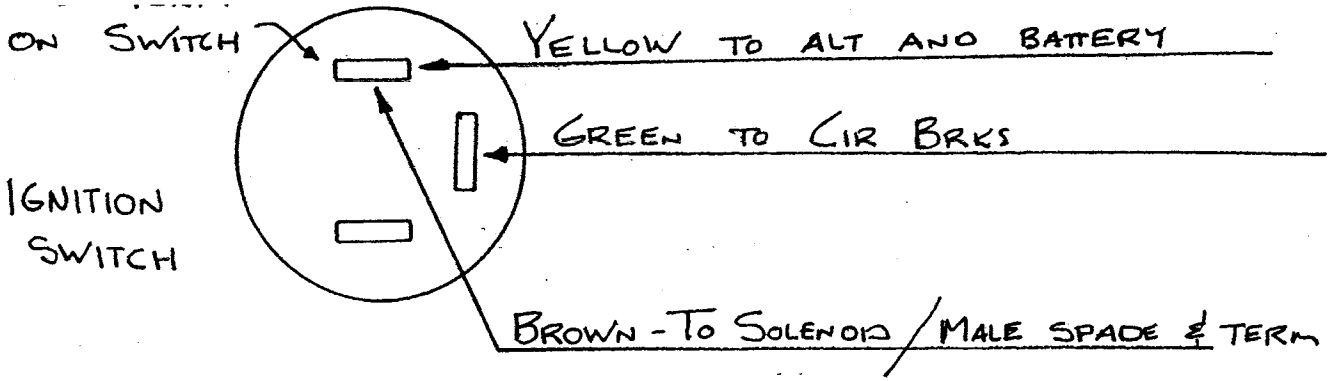

2. Brush the solution over the battery top, including terminals and cable clamps. Make sure the solution does not enter the battery.
3. Using a wire brush, clean the terminal posts and cable clamps.
4. Apply a thin coating of vaseline to the terminals and cable clamps.

BATTERY REPLACEMENT



CAUTION:

Remove the negative battery cable before you remove the positive battery cable. This is done to prevent accidental electrical shorting which can result in personal injury.

1. Disconnect the negative (-) cable and then the positive (+) cable.
2. Remove the battery.
3. Install new battery.
4. Connect the positive (+) battery cable first, then the negative (-) cable.

FUEL SYSTEM

To keep engines in good condition:

- Fill the fuel tank at the end of each day to prevent condensation from forming in the fuel tank. Use clean gasoline of at least 85 octane.
- Replace the fuel filter every 500 hours of use.

NOTE: The PowerBoss™ uses an in-line fuel filter located in front of the fuel pump.

For additional information on the carburetor and fuel pump, refer to the engine service manual furnished with this manual.

SERVICE INSTRUCTIONS



WARNING: Never attempt to perform any service on the equipment or components until the engine is OFF, the parking brake is LOCKED, and the wheels are CHOCKED.



WARNING: Never bypass safety components unless you are testing them.



WARNING: Replace any defective safety components before operating the sweeper.



WARNING: During repair or servicing of the fuel system, work in a properly ventilated area and do not smoke or allow an open flame near the fuel system.

COOLANT SYSTEM

The normal operating temperature of the engine is 180° - 200°. Abnormally high operating temperatures and overflow loss commonly indicate the radiator is clogged with rust and sludge or radiator fins are clogged with dirt. In this situation, you may want to use the reverse flow flushing procedure listed below. Reverse flow flushing is performed after the radiator has been flushed with a cleaning compound.

The following maintenance is required to keep the coolant system operating efficiently:

- Check the coolant level each day.
 - Drain and flush the coolant system every 500 hours of operation.
 - Inspect the radiator fins for cleanliness every 50 hours of operation. Blow out the radiator fins if clogged.
-

SERVICE INSTRUCTIONS



WARNING

Never attempt to perform any service on the equipment or components until the engine is OFF, the parking brake is LOCKED, and the wheels are CHOCKED.

BLOWING OUT RADIATOR FINS

NOTE: Make sure the radiator is cool before blowing out the radiator fins with compressed air.

REVERSE FLOW FLUSHING

1. At the engine, disconnect the hoses.
2. Make sure the radiator cap is on tight.
3. Using a hose clamp, clamp a flushing gun onto the lower hose.
4. Turn on the water and fill the radiator.
5. To keep from damaging the radiator, apply air pressure slowly and carefully.
6. Shut off the air pressure, refill the radiator with water, and reapply the air pressure. You will need to repeat these steps until water flushed from the radiator runs out clear.

7. Inspect and clean the radiator cap.
8. Inspect and reconnect the hoses.
9. Refill the radiator with coolant.

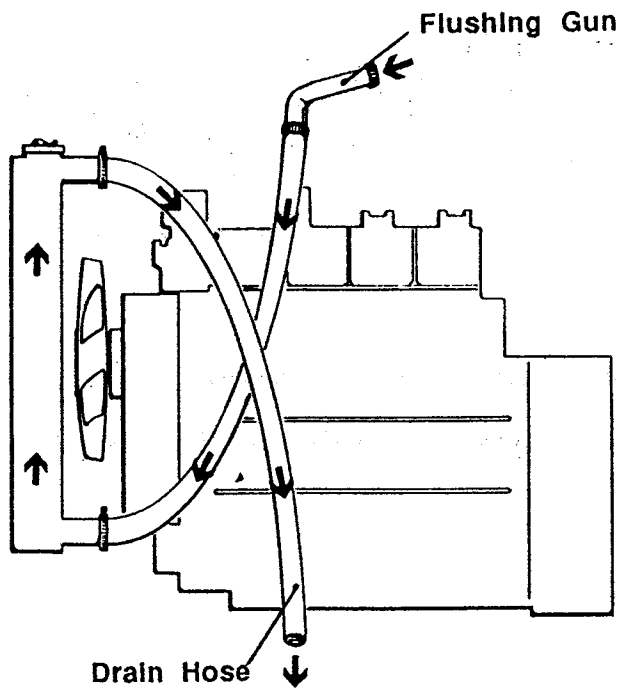

NOTE: Use a 50/50 mixture of water and an anti-freeze with an ethylene glycol base.

LUBRICATION

Lubrication on PowerBoss™ sweepers requires the following:

- Check the engine oil level each day.
 - Replace engine oil and filter every 100 hours, or more frequently in extremely dusty operating environments.
 - Use oil which meets API SD or SE specifications, and which is suited to seasonal temperatures. (Refer to charts below.)
 - Follow the recommended lubrication schedule for bearings, grease fittings, and other key lubrication points.
-

Gasoline Engines: Use any SAE rated oil meeting API specifications and suited to seasonal temperatures.

Temperature	SAE Viscosity
Below 0° F (Below -17° C)	SW-20, SW-30
0 to 75° F (0 to 24° C)	SW-30, 10W, 10W-30, 10W-40, 20W-20, 20W-40
Above 75° F (Above 24° C)	10W-50, 20W-50

SERVICE INSTRUCTIONS



WARNING: Never attempt to perform any service on the equipment or components until the engine is OFF, the parking brake is LOCKED, and the wheels are CHOCKED.

CHANGING ENGINE OIL

NOTE: The engine oil drain plug is located at the bottom of the engine pan.

1. Raise the hopper and engage the safety arm.

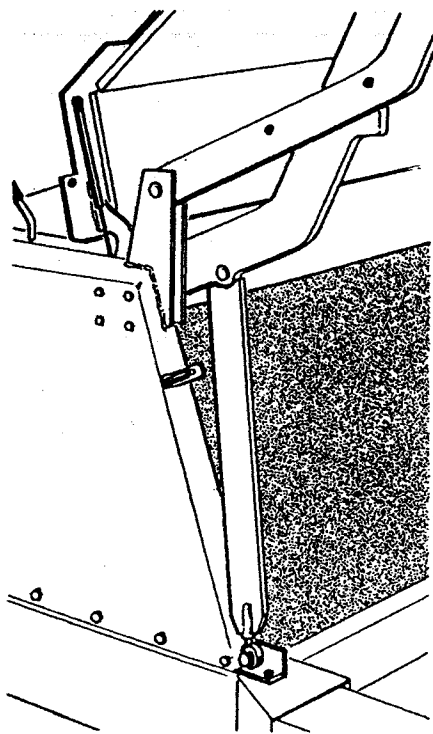

WARNING: Never place your hands or body parts under a raised or partially raised hopper unless the safety arm is in place.

2. Remove the drain plug and allow oil to drain into the pan.
3. Replace the drain plug.
4. Remove the used oil filter and replace with a new one.
5. Remove the engine oil cap, add oil in the amounts listed in engine manual, then secure the cap.

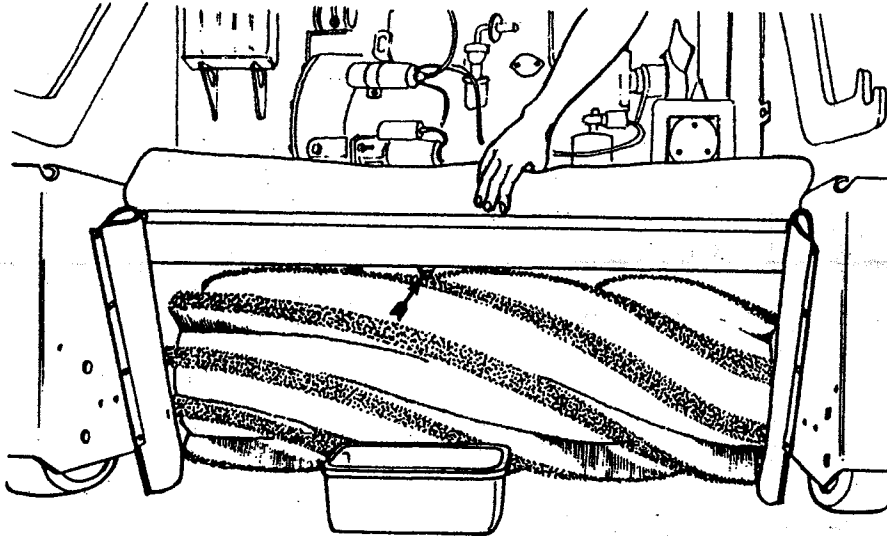

LUBRICATION POINTS

The chart on the next page outlines additional lubrication requirements for PowerBoss™ sweepers. Refer to the chart for assistance in locating key lubrication points.

LUBRICATION CHART

Lubrication	Type of Lubrication	Frequency (In Hours)
Impeller Bearing Housing (1 fitting)	Lubriplate EMB or Chevron SR1 #2	

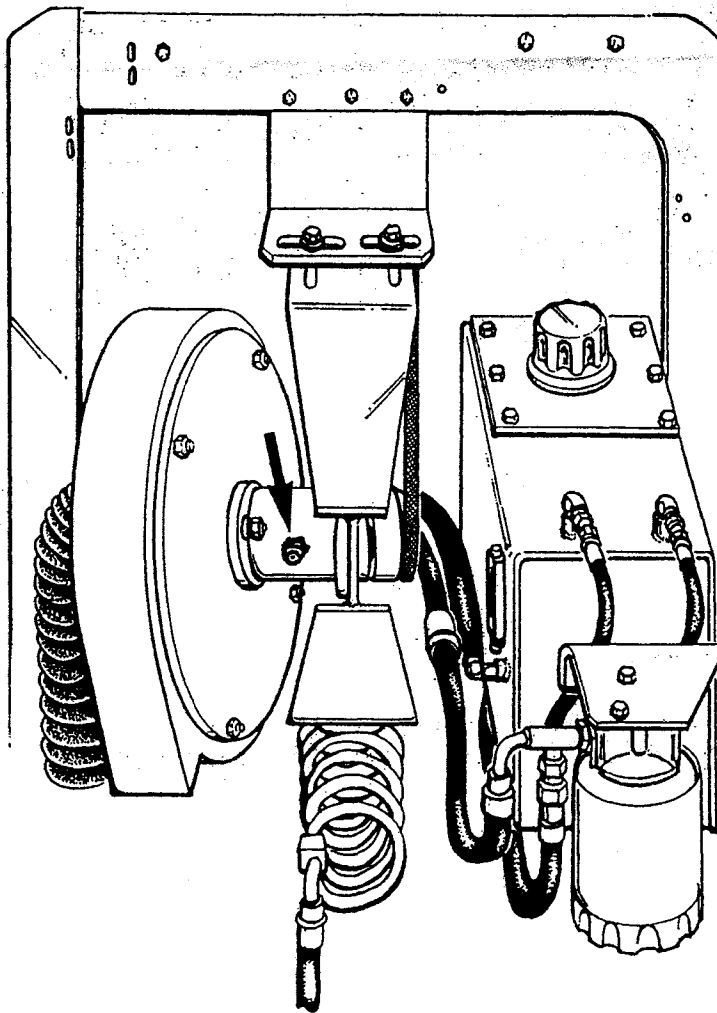

Lubrication	Type of Lubrication	Frequency (in Hours)
Steering Gear Box, (1 fitting) Steering Link Arm, (2 fitting) Steering Fork Assembly (1 fitting)	Lithium Grease	500

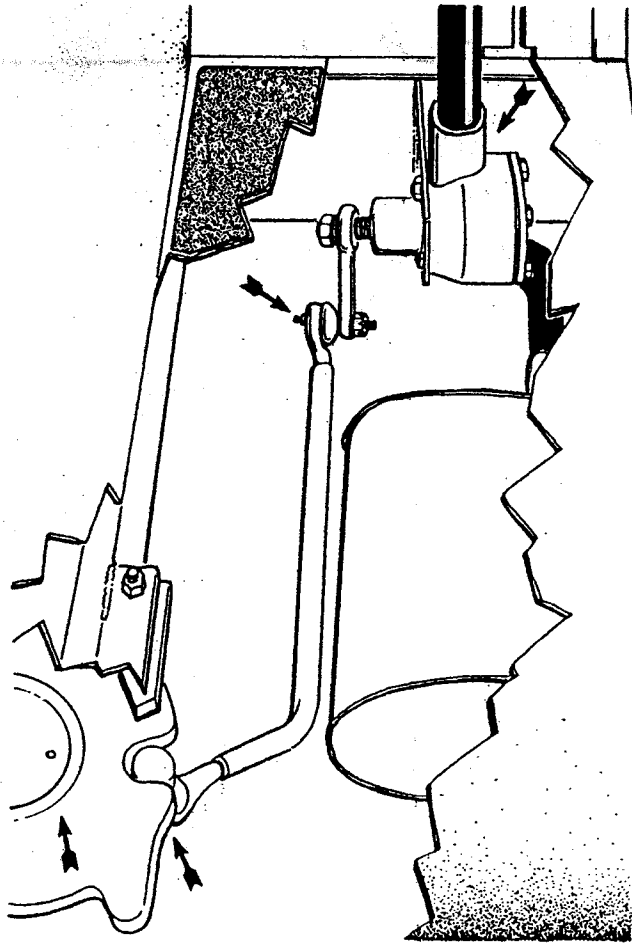

Lubrication	Type of Lubrication	Frequency (in Hours)
Pillow Block Supporting Dump Mechanism (2 fittings)	Lithium Grease	500

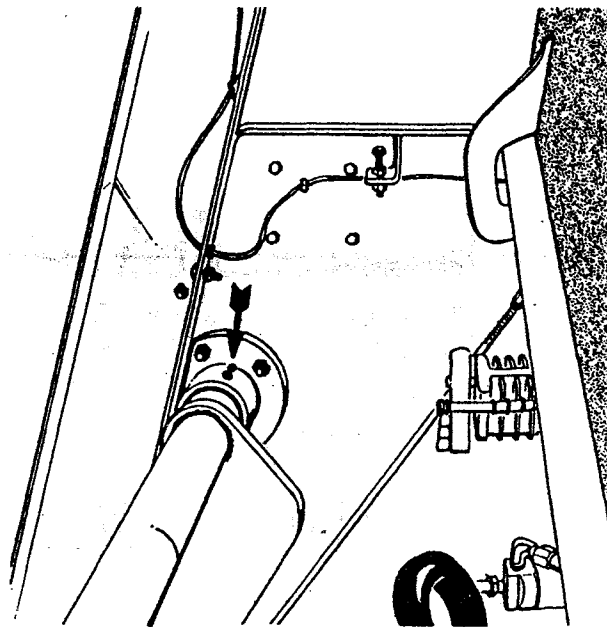

Hood Latches and Hinges	Oil	500
-------------------------	-----	-----

HYDRAULICS SYSTEM

To keep the hydraulics system in good condition, the following maintenance is required:

- Check the sight gauge of the hydraulic fluid reservoir daily and fill the reservoir as needed.
 - Blow off and pressure wash the cooling coil (located at the exit port of the impeller fan) every 100 hours of operation.
 - Change the hydraulic fluid and filter every 500 hours of operation.
 - Check the functioning of the directional control pedal periodically and adjust the neutral setting position and the speed limiter if needed.
-

SERVICE INSTRUCTIONS



WARNING: Never attempt to perform any service on the equipment or components until the engine is OFF, the parking brake is LOCKED, and the wheels are CHOCKED.

FILLING THE FLUID RESERVOIR

NOTE: The reservoir is located inside the machine and is accessible when rear cover is tilted back. When the machine is cool and the hopper is in the lowered position, the sight gauge on the face of the reservoir should be two-thirds full.

1. Remove the cap located on top of reservoir.
2. Fill the reservoir until the sight gauge is two thirds full with fluid that meets the viscosity specifications indicated below, then replace the filler cap.

NOTE: Do not use transmission fluid in place of hydraulic fluid.

Hydraulic Fluid Viscosity Specifications

SUS @ 100° F	404-445
SUS @ 210° F	78-84

MAINTAINING COOLING COIL EFFICIENCY

The cooling coil is located at the exit port of the impeller fan and utilizes exhausted impeller air to cool the hydraulic fluid. To maintain its efficiency, periodically blow off the cooling coil with compressed air and pressure wash the cooling coil every 100 hours of operation.

CHANGING THE HYDRAULIC FLUID

1. Turn off the engine and engage the parking brake.
2. Place a drain pan on the floor below the reservoir.
3. Remove the drain plug located on the bottom rear of the reservoir and allow the fluid to drain.
4. Discard the fluid, then replace and retighten the drain plug.
5. Remove the filler cap located on top of the reservoir and fill the reservoir with approved hydraulic fluid.

NOTE: This will require six gallons of fluid.

6. Check the sight gauge to insure the proper two-thirds level is achieved.
7. Put the cap back on.
8. Check the drain plug for leakage.

A - Cap

B - Hydraulic Reservoir

C - Hydraulic Level Sight Gauge

D - Hydraulic Filter

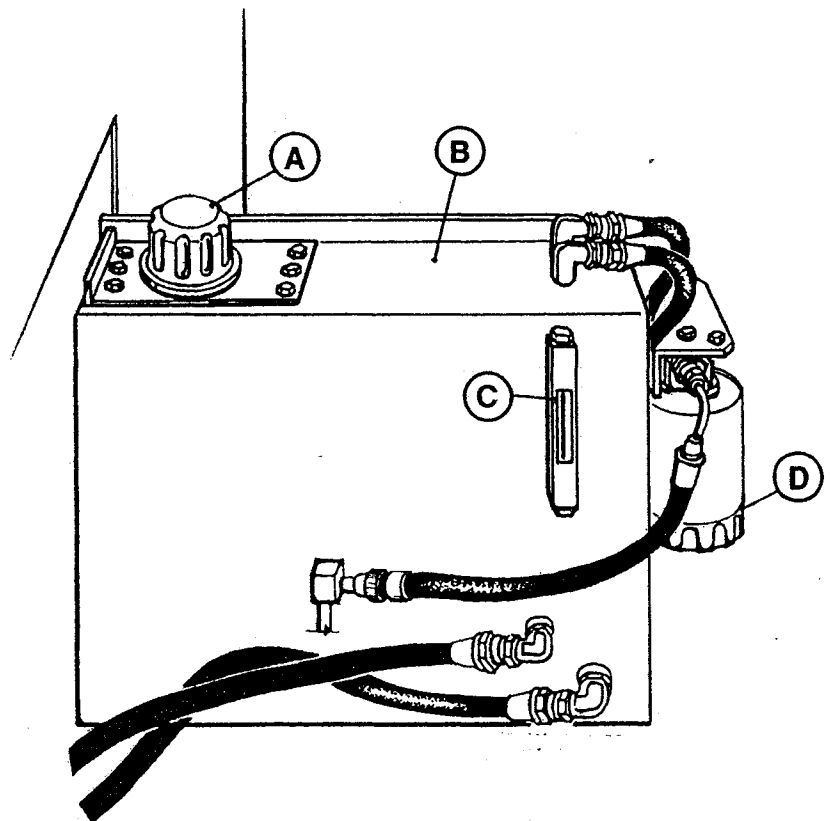

CHANGING THE HYDRAULIC FLUID FILTER

1. Turn off the engine and engage the parking brake.
2. Unthread the oil filter cartridge from the mount and discard.
3. Apply a thin coating of fluid to the seal of a new filter element.
4. Thread onto the mount and hand tighten.
5. Tighten an additional one-half turn beyond hand tight.

NOTE: Do not overtighten.

6. Start the machine, shut it off, then check for leakage.

ADJUSTING THE DIRECTIONAL CONTROL RETURN SPRING

You may encounter "creeping" problems from time to time. Creeping means the machine moves backward or forward when the forward/reverse pedal is in neutral. A grinding noise when the engine is shut down is also an indicator that the directional control return spring needs adjusting. If this occurs, perform the procedure which follows.

1. Raise the hopper and engage hopper safety arm.



CAUTION: For maintenance on the sweeper, do not rely on the hydraulic cylinder to keep the hopper raised. Always engage the safety arm before going under the hopper.

2. Turn off engine, engage parking brake, and chock both wheels.
3. Jack the rear of the machine so that the rear tire just clears the floor. Use two jack stands to support the machine. **DO NOT USE JACK ALONE TO HOLD THE MACHINE UP.**
4. If an assistant is not available to watch the rear wheel, use a mirror to allow you to see the rear wheel.

(Continued on next page.)

5. Locate the forward/reverse adjustment bracket mounted beneath the pump on the pump mounting plate.

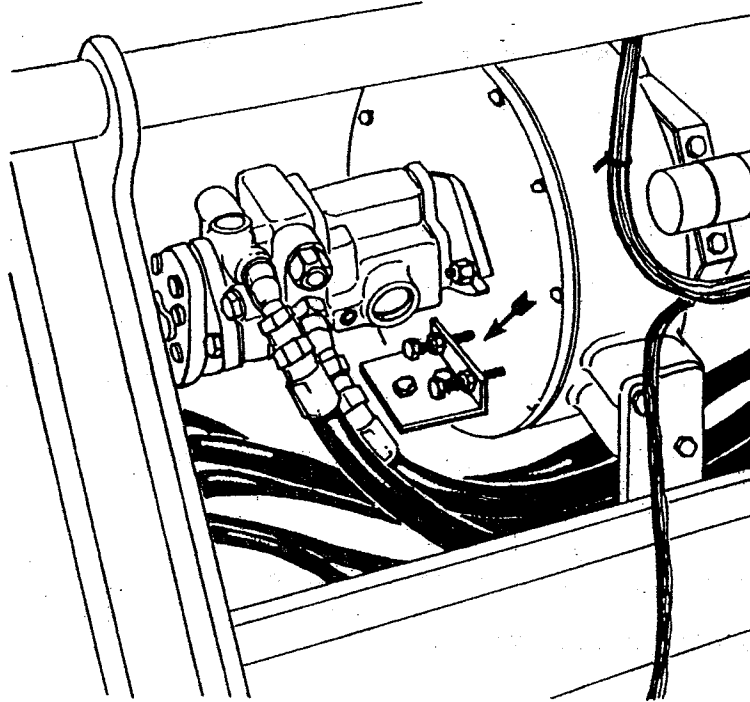

6. Slightly loosen the bolt on the center of the bracket.
7. Now loosen the locking nut on each of the adjusting bolts on the side of the bracket closest to the pump mounting plate.
8. From the operator's seat, start the engine and run at half throttle.
9. Turn the adjusting bolts while watching the rear wheel. Continue to adjust until the rear wheel does not turn in either direction.
10. Fully open throttle. Push the directional control pedal forward and backward to be sure pump stays in neutral. Check wheel again and adjust as needed until the wheel remains motionless.
11. Retighten all the locking nuts and the bolts.
12. Turn engine off and lower the machine to the floor.

ADJUSTING MACHINE SPEED

To limit the speed of the machine, simply reposition the speed limiter, a bolt underneath the directional control pedal which can be moved in or out. Be sure that the directional control pedal contacts the speed limiter bolt before the pump control arm hits the pump stop.

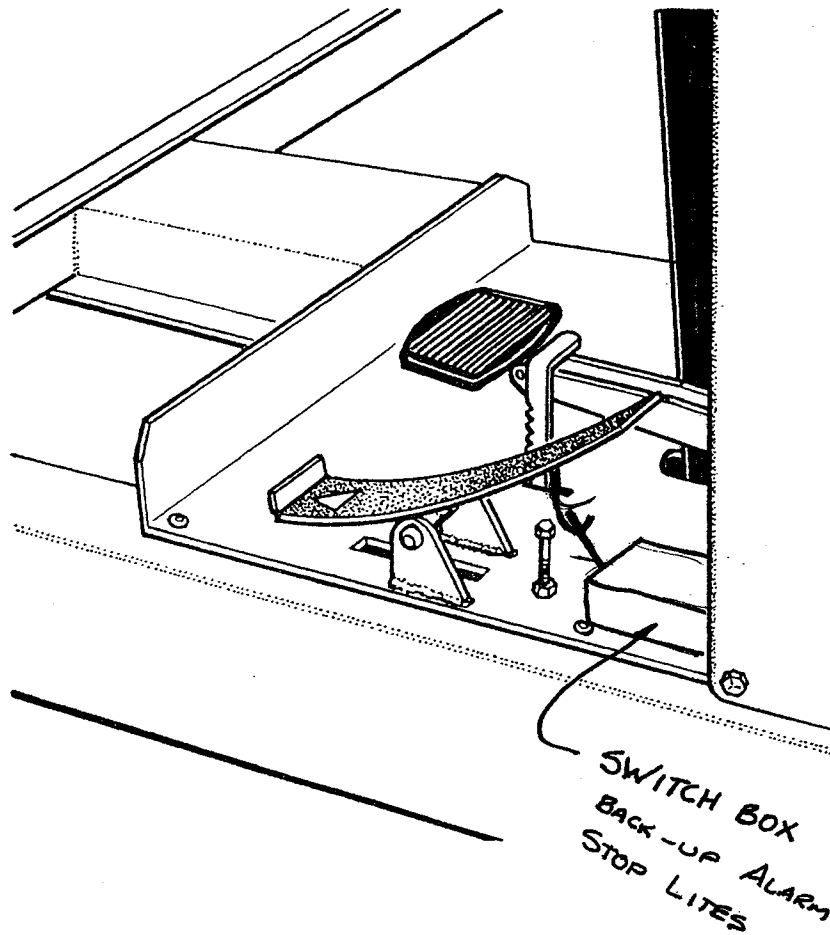

HYDRAULIC SCHEMATIC

Use the schematic which follows to assist you in troubleshooting and maintaining the hydraulics system of the sweeper.

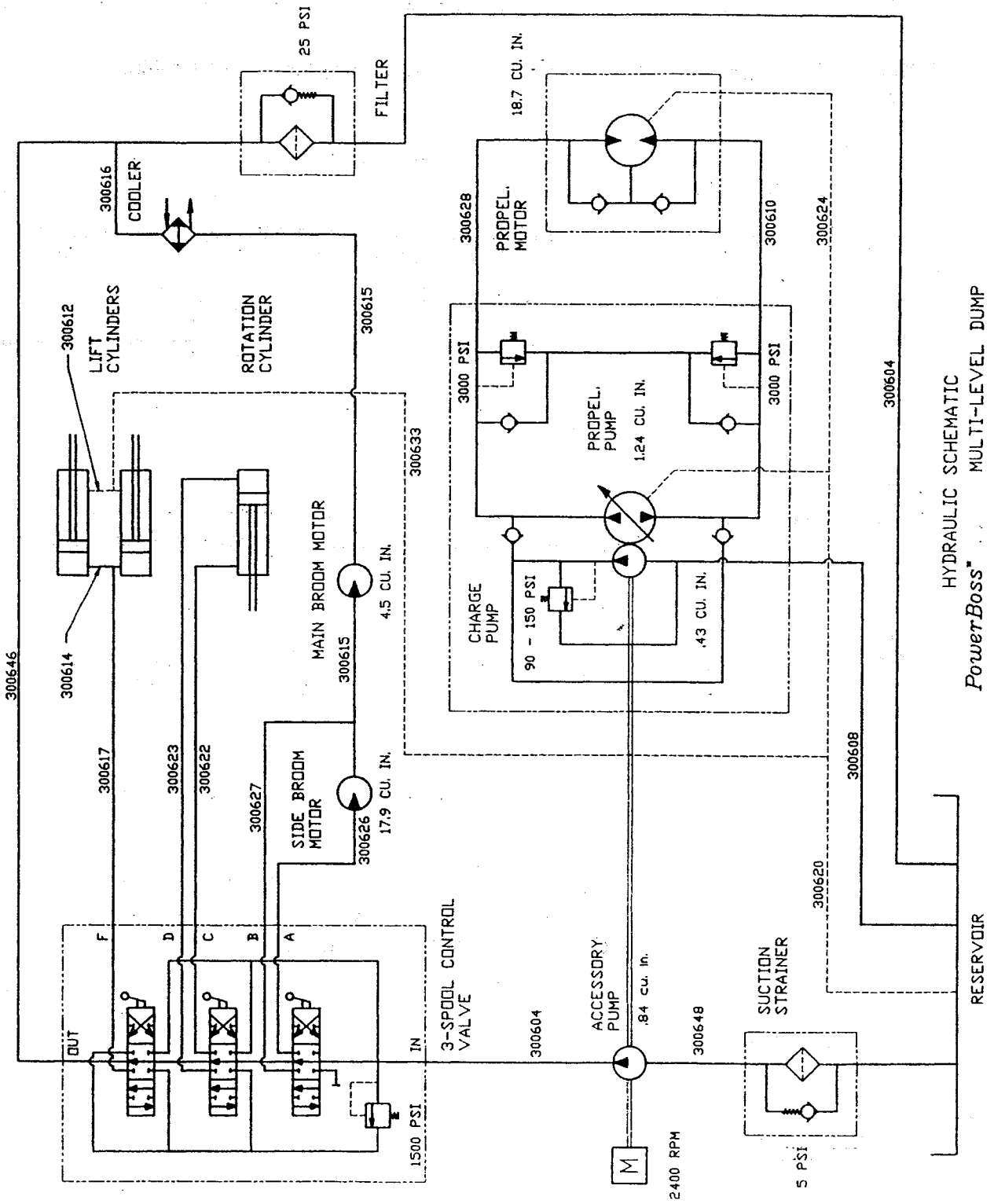

HYDRAULIC SCHEMATIC
PowerBoss™ MULTI-LEVEL DUMP

VACUUM SYSTEM

To keep the vacuum system in good condition, you will need to perform the following maintenance:

- Check the tension of impeller belt after every 50 hours of operation and tighten the belts as needed.
 - After every 100 hours of operation, check to make sure the pulley is aligned with the pulley on the engine. If pulley is not properly aligned, belt cannot properly function.
 - Lubricate impeller bearing housing after every 100 hours of operation.
-

SERVICE INSTRUCTIONS



WARNING: Never attempt to perform any service on the equipment or components until the engine is OFF, the parking brake is LOCKED, and the wheels are CHOCKED.



CAUTION: If the engine must be started for test purposes, do not put your hands near intake hoses or openings or near the impeller or belts.

BELT TENSIONING

1. Loosen center nut and bolt located at the base of the impellar mount assembly. Back the nut off several turns.
2. Loosen both of the nuts on the set screw bolts located on either side of the bolt in Step 1.
3. To tighten belt, alternately tighten the two outside set screw bolts inserted at the base of the impellar mount assembly until proper tension is achieved.
4. Retighten the nuts on each set screw bolt.

(Continued on next page.)

5. Retighten center bolt and nut.

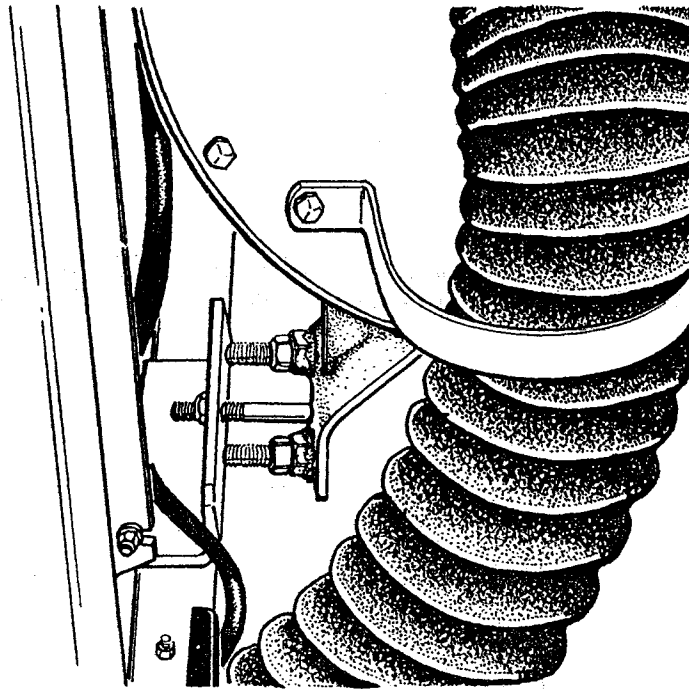

PULLEY REALIGNMENT

1. Check pulley alignment by placing a straight edge against and between the two pulleys. The straight edge should lie flat against the outer surface of both pulleys. If a gap between pulley and straight edge is evident at either end, an adjustment is needed. Alignment can be achieved by using the adjustment slots located on top of the impellar mount assembly.
2. Using a pencil, make a mark where the impellar mount bracket (indicated by A in illustration) overlaps the impellar mount assembly (B in the illustration).
3. Loosen center nut and bolt located at base of impellar mount assembly, back nut off several turns.
4. Loosen both of the nuts on the set screw bolts located on either side of the bolt in Step 2.
5. Loosen the set screws. This will loosen the belt tension.
6. Loosen the two retainer bolts on top of the impellar mount bracket. With these two bolts loose, the impellar mount assembly can be moved in or out to achieve proper alignment.
7. Before retightening the two bolts on top of the assembly, check to be sure pencil line made in Step 2 is still in the same place in relation to impellar mount bracket. Tighten the two bolts on top of the assembly.

8. To retension belt, alternately tighten the two outside set screw bolts at base of impeller mount assembly until proper tension is achieved.
9. Retighten nuts on each set screw bolt.
10. Retighten center bolt and nut.

LUBRICATION OF IMPELLER BEARING HOUSING

1. Grease bearing housing with Lubriplate EMB or Chevron SR1 #2.

ATTENTION! Be careful not to overfill the housing. This will cause grease to be thrown onto the belt and pulley which drive the impeller. Any excess grease expelled from these bearings should be wiped away.

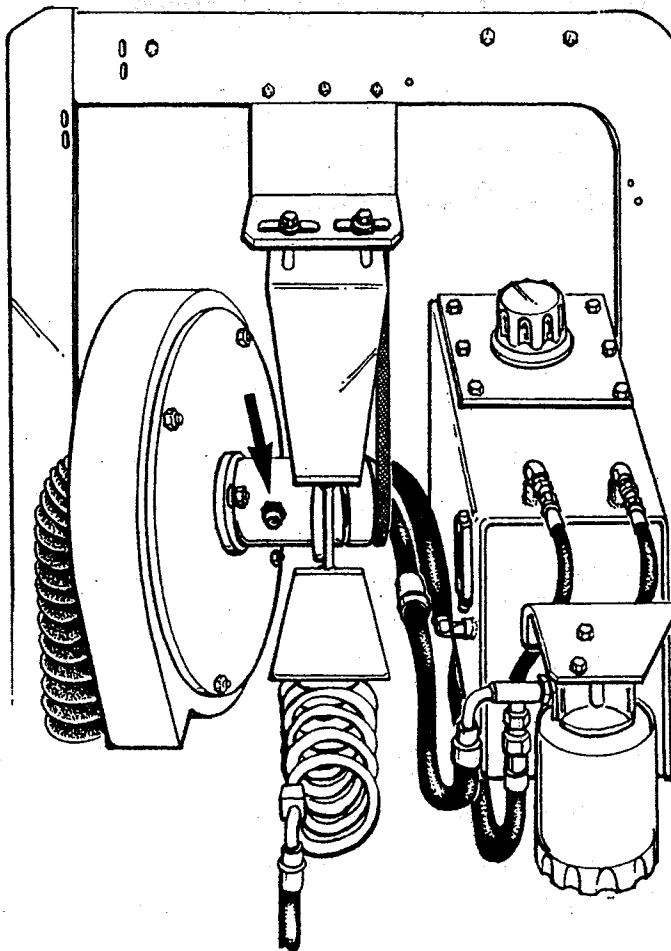

SWEEP COMPONENTS

The following maintenance is required to assure maximum cleaning efficiency and service life of sweep components:

- Inspect brooms daily for wear. Remove any strings, wires, or other debris entangled in the bristles or drive assembly.
 - After every 50 hours of operation:
 - Inspect broom skirts for wear and replace as needed.
 - Rotate the main broom end-to-end.
 - Perform the main broom adjustment test and adjust as needed.
 - Inspect the side broom for proper angle and contact and adjust as needed.
 - Perform taper adjustment when the main broom adjustment test indicates it is necessary.
 - Replace main broom when bristles wear to a length of 1". Replace side broom when bristles wear to a length of 3".
-

SERVICE INSTRUCTIONS



WARNING: Never attempt to perform any service on the equipment or components until the engine is OFF, the parking brake is LOCKED, and the wheels are CHOCKED.

BROOM DOOR FLAP INSPECTION

NOTE: Perform this inspection when the machine is parked on a level surface.

1. Turn the machine off and lock the parking brake.
2. Inspect broom door flaps for wear and damage. Flap clearance should be $1/8$ " above the floor.
3. Worn and damaged flaps should be replaced immediately to maintain proper dust control.

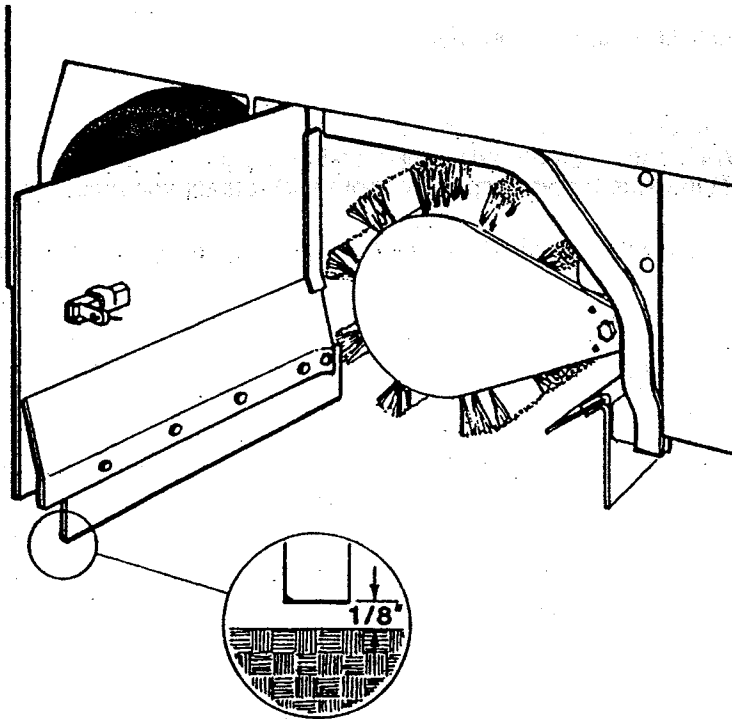

BROOM DOOR FLAP REPLACEMENT AND ADJUSTMENT

The flaps are attached to the broom doors by a retainer bar and hex bolts and nuts. To remove the flaps, remove nuts and bolts and retainer bar. To adjust flaps, loosen nuts and bolts, slide flap up or down as needed. Retighten nuts and bolts.

MAIN BROOM ADJUSTMENT TEST

NOTE: Perform this adjustment on a flat, smooth test surface.

1. Drive the machine onto the test surface with the main broom in the RAISED position.
2. Set the parking brake and position the main broom handle in NORMAL position.
3. Push the broom control lever to ON position to activate the broom motor and open throttle to full RPM.
4. Allow about 45 seconds for the broom to operate, then deactivate the broom motor and raise the broom.

NOTE: Test time will vary according to the test surface used.

5. Drive the machine clear of the test site.
6. Examine the polished pattern made by the broom on the test area.

NOTE: A rectangular shape the length of the main broom, 2" wide, indicates the main broom is properly adjusted. A pattern smaller than 2" indicates need for lower adjustment. A pattern wider than 2" indicates a need for higher adjustment. If pattern is tapered from end to end instead of rectangular, see Taper Adjustment on the next page.

Main Broom Test Pattern

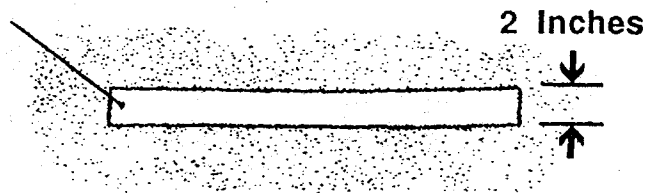

MAIN BROOM ADJUSTMENT

1. Turn the machine off and lock the parking brake.
2. Position the main broom lever in the full FLOAT position.

NOTE: The adjustment knob is located under the engine cover immediately beside the battery on the firewall.

3. Turn the broom adjusting knob clockwise one-eighth turn to free wingnut.
4. Turn the wingnut counterclockwise to allow space for adjustment.
5. Make a lower or higher adjustment with the knob as required.
6. Retighten the wingnut.
7. Repeat the main broom adjustment test to see that the broom is properly adjusted.

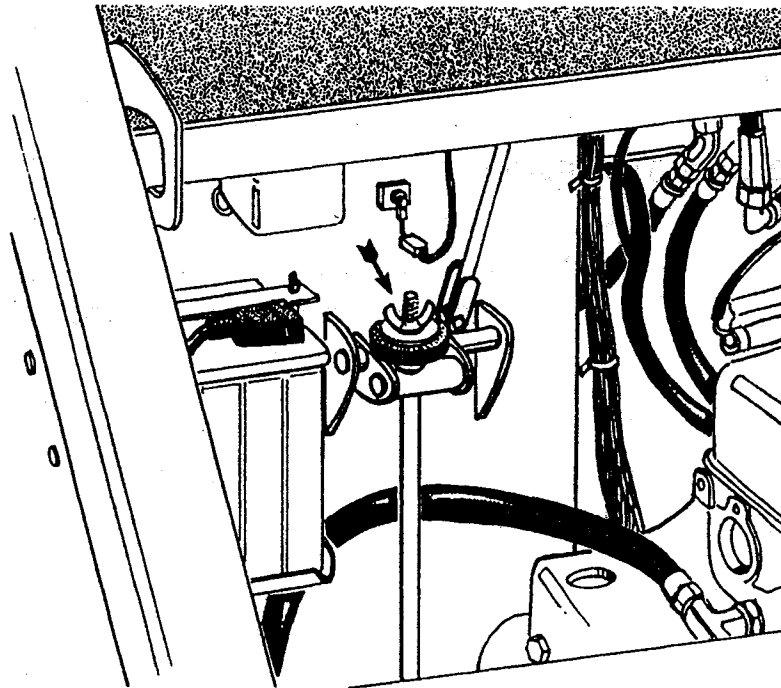

MAIN BROOM TAPER ADJUSTMENT

NOTE: It is not usually necessary to perform this adjustment. However, if the main broom adjustment test shows a pattern that is tapered in length (one end is wider than the other), perform the procedures which follow.

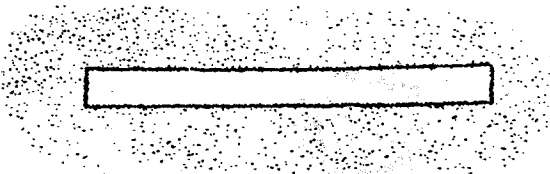

Correct Taper Pattern

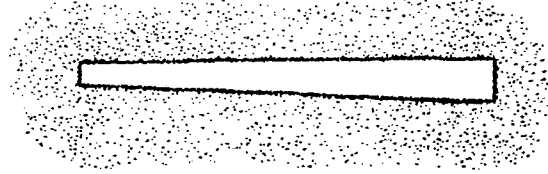

Incorrect Taper Pattern

1. Locate the hex-shaped adjustment bar on the left rear wall of the broom chamber underneath the machine.

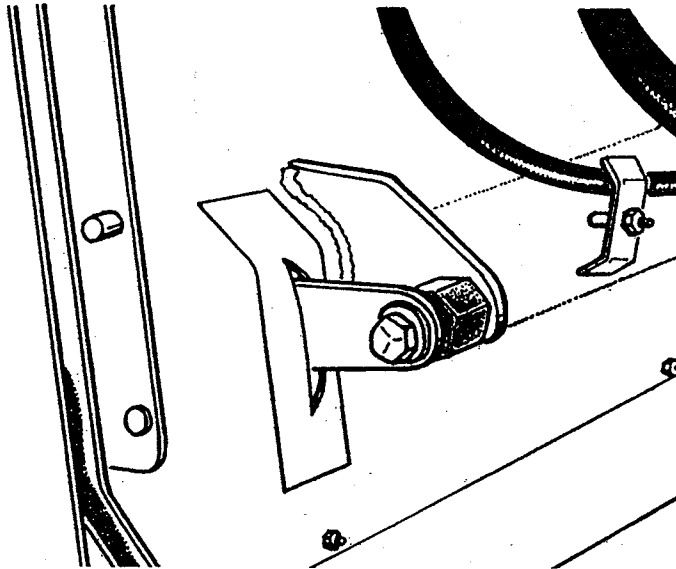

2. Loosen the locking bolt on the right side of the hex bar.
3. Grasp the hex bar with a wrench and rotate it to raise or lower the left end of the main broom. (The right end of the main broom remains fixed. All adjustments affect the left end of the broom.)
4. After adjustment, retighten the bolt.
5. Repeat the main broom adjustment test to see that the broom is properly adjusted.

SIDE BROOM ADJUSTMENT INSPECTION

Inspect the side broom for proper angle and contact with the floor. Optimum side broom angle is 6°. Proper contact is achieved when the bristles contact the floor from 3:00 to 10:00 as shown in drawing.

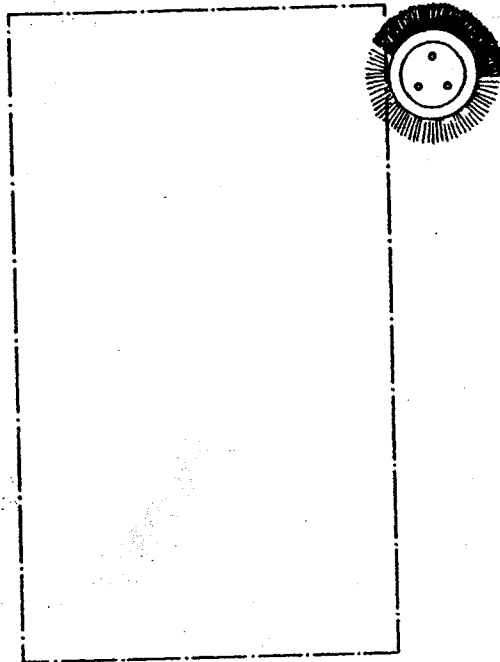

SIDE BROOM HEIGHT (WEAR) ADJUSTMENT

1. Stop the engine and lock the parking brake.
2. Position the side broom handle in LOWER position.
3. Loosen the side broom adjusting nuts located on the exterior of the side broom arm assembly.

(Continued on next page.)

SIDE BROOM LIFT CABLE ADJUSTMENT

This adjustment is made at the hex-shaped adjustment bar attached to the side broom lift lever in the engine compartment. It controls the height of the side broom when raised.

This adjustment must be performed with the hopper fully lowered.

1. Pull the side broom lever into the raised position.
2. Loosen the locknut on the hex bar.

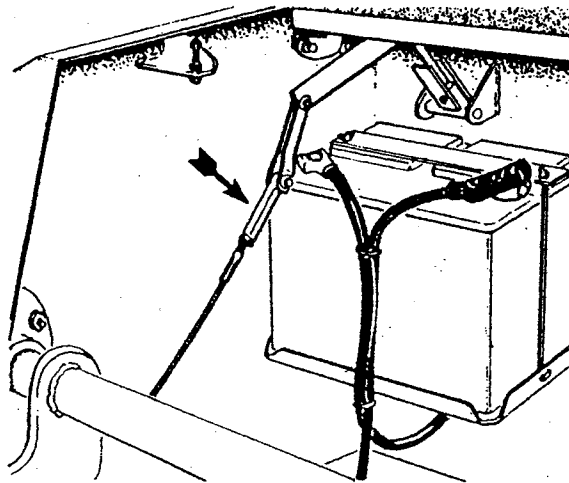

NOTE: ON SW 70
BATTERY LOCATED
IN REAR CLIP

3. Turn the cable in or out of the hex bar as necessary to set the side broom in the maximum raised position.
4. Secure the cable adjustment by tightening the locknut against the hex bar.

MAIN BROOM REPLACEMENT

1. Turn the engine off and lock the parking brake.
2. Push the main broom control lever to the NORMAL position.
3. Open the left broom chamber door (the door opposite the driver's side).
4. Using a wrench, remove the hex bolt on the main broom idler mount.
5. Pull the main broom idler mount straight out to remove.

6. Grasp the main broom by the plastic drive hub, pull the main broom straight out and clear of the broom chamber.
7. At this point, depending on broom condition, you can either rotate the old broom end-for-end and re-install it or you can install a new broom. In either case, you need to slide the main broom into the broom chamber and align the broom with the metal drive hub located at the far side of the broom chamber.

If a worn broom is being replaced, it may be easier to install the new broom by first adjusting the broom arms up, to better match the position of the drive hub with the hub on the new broom.
8. Once the broom is started onto the drive hubs, rotate the broom counterclockwise while pushing lightly against the broom.
9. Once the broom is fully engaged, replace the idler hub while aligning the seats in the idler hub with the broom's drive hub ears.
10. Install the retaining bolt into position and tighten with the wrench.
11. Close and latch the left broom door.
12. Perform a main broom adjustment test and adjust as needed.

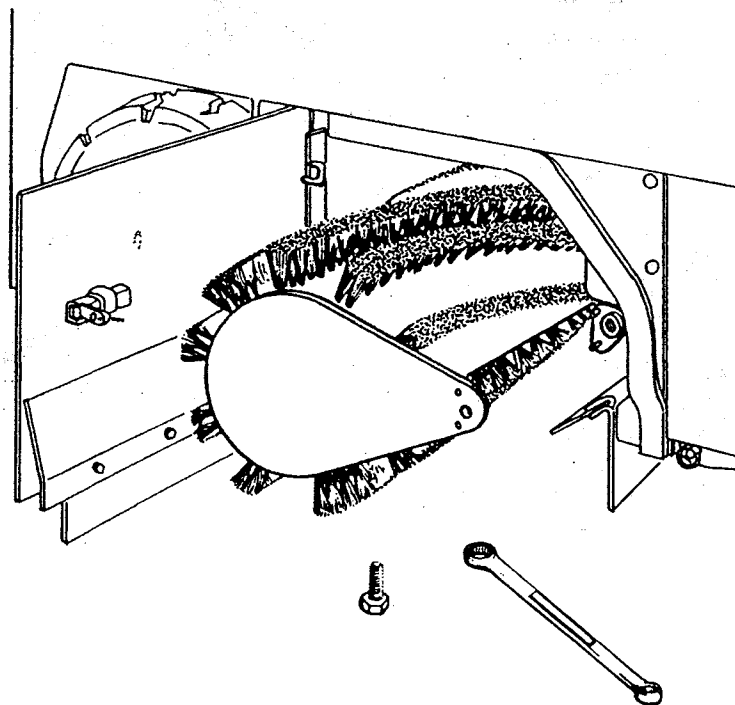

SIDE BROOM REPLACEMENT

1. Raise the side broom and lock in RAISE position.
2. Loosen the three bolts which hold the broom in place and remove the broom.
3. Install the new broom and bolt in place.

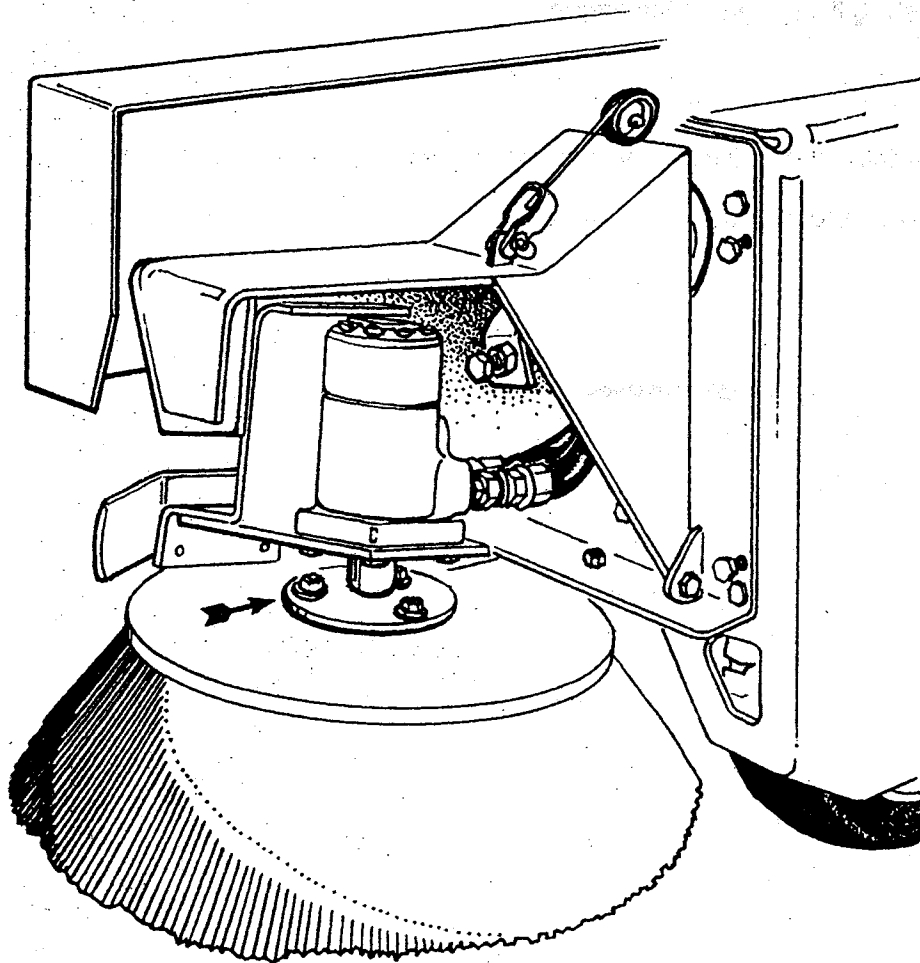

HOPPERS

The following maintenance is required to assure maximum cleaning capacity of hoppers and tanks:

- Check hopper filters and clean or replace as needed.
 - Check hopper clearance from floor and adjust as needed.
 - Inspect hopper flaps daily for wear and damage and replace when needed.
 - Lubricate the dump mechanism every 500 hours of service.
-

SERVICE INSTRUCTIONS



WARNING: Never attempt to perform any service on the equipment or components until the engine is OFF, the parking brake is LOCKED, and the wheels are CHOCKED.

HOPPER REMOVAL AND REPLACEMENT

It is not usually necessary to remove or replace the hopper. However, if it becomes necessary for maintenance or to install an option, use the following procedure to remove:

1. Park the machine on a level surface and engage the parking brake.
2. Raise the hopper and position the hopper dolly, a platform truck or similar four wheeled cart under the hopper.
3. Set the hopper down on the truck and turn the engine off.
4. Cycle the rotation control handle (#2) in both positions to relieve any residual hydraulic pressure.
5. Remove the three bolts and bushings located on both sides of the hopper. Be careful not to lose the bushings that are in each of the bolt holes.
6. Disconnect the wire connections at the right side of the hopper.
7. While spreading dump arms slightly, roll the hopper away from machine.

To replace:

1. With the hopper on the dolly, roll the hopper back into position between the rotation mounts on the arms. Lift arms should be positioned about 1/3 of way up.
2. Align lift arm rotation plates with three mounting holes on each side of the hopper.

NOTE: The right rotation plate may have to be repositioned hydraulically to align holes.

3. Place the bushings in the holes in the hopper rotating plate and bolt the hopper back in place.

NOTE: Rotation mounts have holes that must engage bolt heads on side of hopper prior to threading in spindles.

4. Start the machine and lift hopper.
5. Drive the truck away from the hopper dolly or cart.
6. Lower hopper.
7. Engage wire connections at right side of hopper.

FILTER REMOVAL

1. Release the two latches on the hopper cover and raise cover.
2. Disconnect the wire harness leading to the filter shaker motor.
3. Unscrew the four bolts securing the shaker motor mount to the hopper.
4. Remove the shaker motor assembly.
5. Lift out the panel filter.

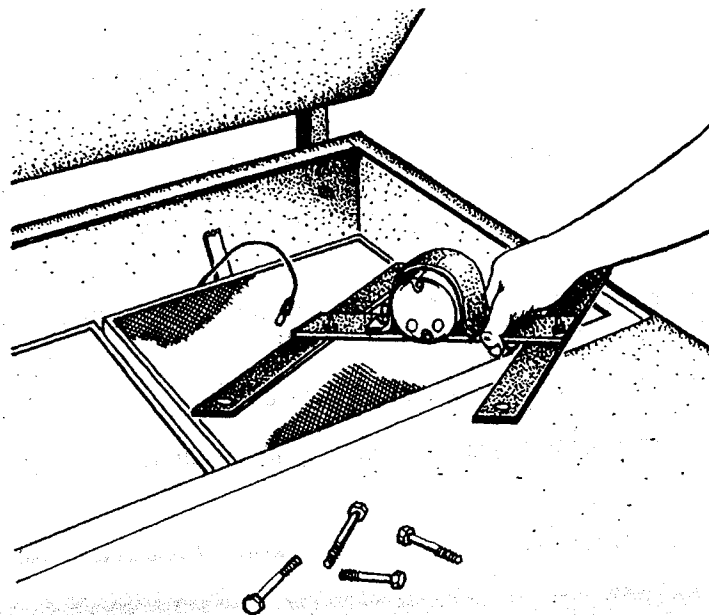

FILTER CLEANING

The filter is a permanent type paper element filter. A filter may be vacuumed, blown out with compressed air, tapped against the floor, or washed with soap and water.

1. If blown out with compressed air, use 100 psi or less.

NOTE: Filter may be blown out while installed or removed.

2. If washed with soap and water, use 40 psi water pressure or less.

NOTE: Make sure filter is thoroughly dried while standing on its side before installing in the hopper. Do not install or use a wet filter.

FILTER REPLACEMENT

1. Insert the panel filter.
2. Install the shaker motor assembly.
3. Install and tighten the four filter retaining bolts.
4. Hook the wire harness to the filter shaker motor.
5. Close the hopper cover and secure the latches.

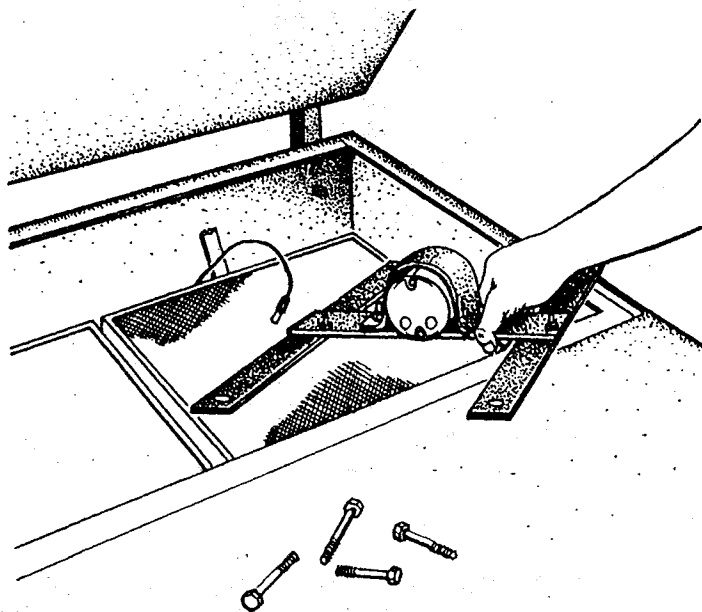

HOPPER FLOOR CLEARANCE AND DUMP ADJUSTMENTS

In order to perform properly, the hopper must maintain a distance of 3-1/2" from the floor to the rear hopper entrance lip. The front of the hopper should be adjusted so that the front bumper aligns with the hopper frame where the two meet. When properly adjusted, the front edge of the hopper will be 5" to 6" from the floor.

1. Park the machine on a level surface, shut off the engine, and engage the parking brake.



CAUTION:

Do not rely upon hydraulic cylinders to keep hopper raised for maintenance on. Always engage the safety arm before getting under the hopper.

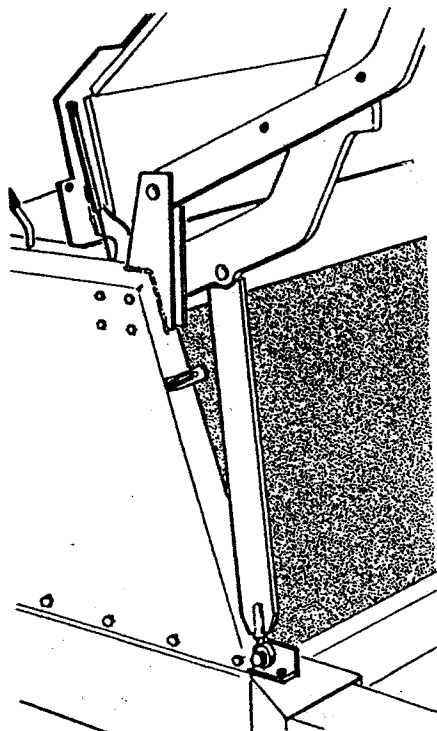

2. Adjust the lift arm stop bolts located on top of the wheel wells as low as possible while still allowing the side broom assembly to clear the lift arms when the hopper is in normal position. Be sure that both lift arms contact the stop bolts at the same time.

NOTE: This may involve raising and lowering the hopper several times.

3. After adjustment, with the hopper down, use the two adjustable stops located on the rotation plates on both sides of the hopper to establish 3-1/2" clearance between the rear hopper entrance lip and the floor.

NOTE: The stop on the driver's side is located immediately below the cylinder rod end and is threaded into the cylinder mount arm. The stop on the left side is located directly above the arm rotation plate.

(Continued on next page.)

4. After the 3-1/2" clearance is established, make sure both stops make contact simultaneously. The lower front edge of the hopper should be 5" - 6" from the floor. A balanced adjustment of both sets of adjustment bolts is required to correctly adjust the hopper in the lowered position. If the bumper is lower than the frame, after the hopper is correctly adjusted, loosen the bumper attachment bolts and reposition the front bumper.
5. Next, raise the hopper and rotate fully.
6. Turn the engine off.



CAUTION: Do not rely upon hydraulic cylinders to keep hopper raised for maintenance. Always engage safety arm before getting under the hopper.

7. Adjust the stops on the hopper mounts on each side of hopper so that clearance between the lift arms and the cut outs in bumper is 1/4" maximum.
8. Loosen the locking set screw in the bottom side of the rotation cylinder rod end.
9. Using the hole in the cylinder rod, turn the rod to adjust cylinder extended length to match hopper rotation stops.
10. Tighten the set screw.
11. Rotate the hopper back, remove the safety arm, and lower the hopper.

HOPPER VACUUM GASKET MOUNT ADJUSTMENT

1. With hopper in normal position, observe contact between back of hopper and gasket. If complete seal is not maintained, raise hopper.



CAUTION: Do not rely on hydraulic cylinders to keep the hopper raised for maintenance. Always engage the safety arm before getting under the hopper.

2. Loosen mounting bolts in gasket mount. Move assembly toward hopper. Tighten bolts. Test and repeat if necessary.

HOPPER FLAP REPLACEMENT

Flaps located at the entrance lip of the hopper, and on the sides of the hopper, must be replaced when worn or damaged. The flap panels may be replaced separately.

1. Park the machine on a level surface and engage the parking brake.
2. Raise the hopper.



CAUTION: Do not rely on hydraulic cylinders to keep the hopper raised for maintenance. Always engage the safety arm before getting under the hopper.

3. Turn off the engine.
4. Remove the flap retaining angle and worn or damaged flaps.
5. Install new flaps.
6. Replace the retaining angle.

HOPPER/FRAME SEAL REPLACEMENT

Front Frame Seal

The hopper frame seal bolts to the front edge of the engine pan. Install a new seal by folding it in half to align holes. Doubled edge with holes goes on bottom. Support the seal straight up while bolting the retainer bar in place. The seal should fall over the retainer bar after installation. Be certain that the seal edges are aligned to prevent twisting of the seal.

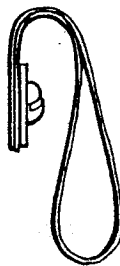
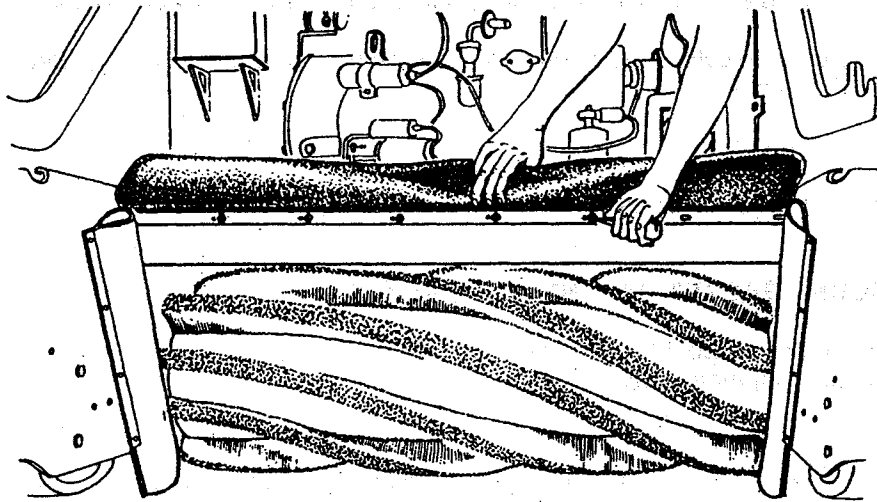

Side Frame Seals

The side frame seals should clear the floor by at least 1/8".

If the bottom of a side seal measures 1/2" or more above the floor, readjust it or replace it by removing the bolts on the inside of the frame wheel wells, installing a new seal, and securing it with the bolts. The double edge with the holes goes toward the front.

STEERING

To keep steering mechanisms safe and efficient, perform the following maintenance:

- Lubricate the grease points on the steering gear box, steering link arm, and steering fork assembly after every 200 hours of operation.
- Check the steering gear box for wear and adjust as needed.



WARNING

Never attempt to perform any service on the equipment or components until the engine is OFF, the parking brake is LOCKED, and the wheels are CHOCKED.

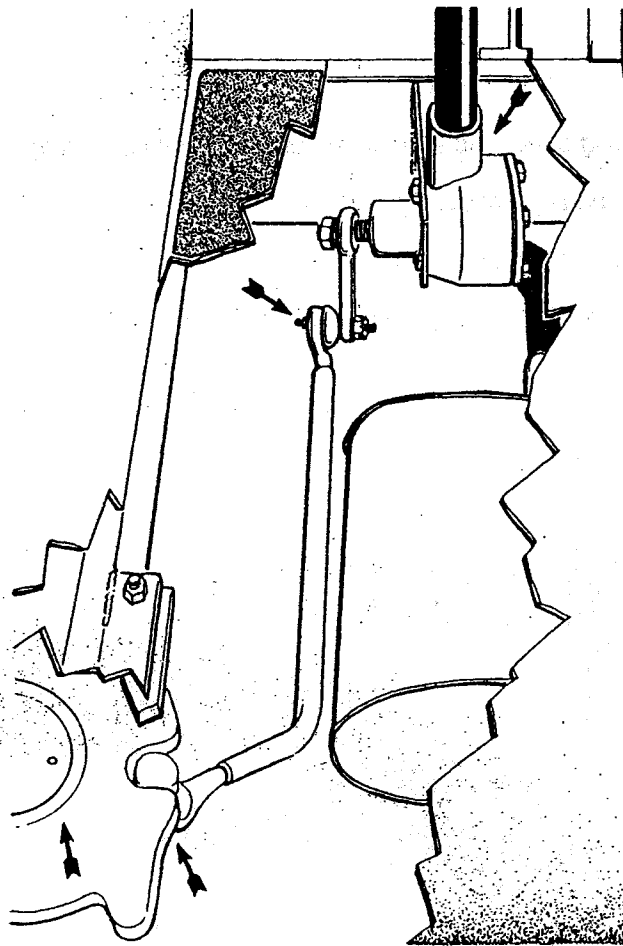

PARKING/EMERGENCY BRAKE

The parking/emergency brake on the SW70 is a set of mechanical contact brakes operated by a cable from the foot pedal. To keep the parking brake functioning safely and efficiently, check to see that it works properly and perform the adjustment explained below when necessary.

SERVICE INSTRUCTIONS



WARNING: Do not attempt to perform parking brake adjustment until engine is OFF and wheels are CHOCKED.

PARKING BRAKE ADJUSTMENT

1. Locate the parking brake cable in the top of the left wheel well opening.
2. Loosen the locking nut located against the hex bar.
3. Thread the cable end as far into the hex bar as needed.
4. If threads are not sufficient for adjustment, move the cable bars to the next adjusting hole on the hex bar.
5. Retighten the locking nut against the hex bar. This adjusts both brake shoes.
6. Test brakes. Readjust if necessary.

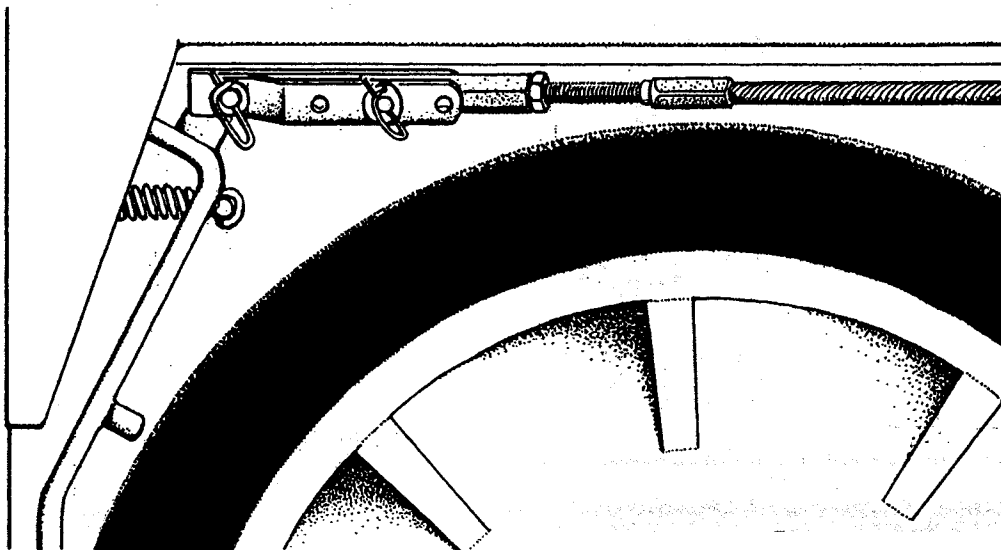

TIRES

PowerBoss™ sweepers use an interchangeable, two-piece, bolt-together cast rim for mounting the rear solid tires. Front tires use one-piece cast rim with a press-on rubber tire. Tire maintenance requires the following:

- Visually inspect tires every day for wear and damage.
-

SERVICE INSTRUCTIONS



WARNING: Never attempt to perform any service on the equipment or components until the engine is OFF, the parking brake is LOCKED, and the wheels are CHOCKED.

CHANGING REAR SOLID TIRES

NOTE: The procedures which follow apply to solid tires only.

1. Remove tire from vehicle by removing the five inner lug nuts.
2. Remove the five flathead bolts and nuts.
3. Press the tire from rim.
4. Press the large rim half into the new tire.
5. Mount the small rim half and secure with flathead bolts.
6. Reinstall tire on machine.

CHANGING FRONT PRESS-ON TIRES

1. Remove grease cap.
2. Take the tire off.
3. Press the old tire off the rim.
4. Press the new tire onto the rim.
5. Put the tire and rim back on the sweeper.
6. Put the spacer, cotter pin and grease cap back on.

MISCELLANEOUS ADJUSTMENTS

- Each machine is equipped with an anti-static drag chain bolted to the back wall of the broom chamber. This should remain in contact with the floor at all times. Inspect the chain every 200 hours. Replace if at least one link does not drag the surface of the floor.
 - Latches and hinges should be inspected after every 500 hours of use. Retighten and oil if necessary.
 - Inspect cables for wear every 500 hours.
-



WARNING:

Never attempt to perform any service on the equipment or components until the engine is OFF, the parking brake is LOCKED, and the wheels are CHOCKED.

TABLE OF CONTENTS
Troubleshooting

Basic Machine Operating Problems..... G-1

Sweeping Problems G-2

Hydraulic System Problems..... G-4

PROBLEM	CAUSE	SOLUTION
BASIC MACHINE OPERATING PROBLEMS		
Engine will not start or runs roughly after start.	Battery dead	Recharge or replace battery.
	Machine out of fuel	Refuel.
	Fuel filter plugged	Clean or replace filter.
	Fuel line broken or obstructed	Blow fuel line out with compressed air.
	Fuel line connection loose	Tighten connection.
	Dirty air filter	Clean or replace air filter. (See Service/Repair Section.)
	Problems with spark plugs, ignition points, ignition coil, ignition switch, carburetor, regulator, wiring harness	Review engine manual at back of this book for maintenance and troubleshooting procedures.
Engine overheats.	Low coolant level.	Supply coolant.
	Clogged radiator.	Flush radiator.
	Loose fan belt.	Tighten belt.
	Defective thermostat.	Replace thermostat.
	NOTE: If coolant loss has not occurred, check for malfunction of the temperature sending unit.	
PowerBoss™ moves slowly or does not move.	Parking brake on	Release brake.
	Directional pedal linkage jammed, damaged, or not adjusted properly	Clear jam or adjust linkage.
	Tires skidding from contact with oil or grease	Clean tires or drive through a solvent absorbing substance.

PROBLEM	CAUSE	SOLUTION
PowerBoss™ moves slowly or does not move. (cont.)	Wheels jammed	Clear jam.
	Low hydraulic oil level	Add oil.
	Hydraulic oil temperature too high and too thin caused by excessive load, climbing, high environment temperatures or worn pump	Use the proper weight of oil for the operation conditions; check pump.
	Damaged or worn pump drive coupling	Replace.
PowerBoss™ creeps in neutral.	Other problems with the hydraulics system: pump failure, motor failure, relief valve leaking or stuck open	See Hydraulics System Problems in this section.
	Directional pedal return spring out of adjustment	Perform the adjustment procedure.

SWEEPING PROBLEMS

Brushes do not turn or turn very slowly.	Hydraulic system problem:	See Hydraulics System Problems in this section.
	<ul style="list-style-type: none"> - motor - control valve - gear pump - relief valve 	
Little or no vacuum in brush compartment.	Filter clogged	Clean filter.
	Leak or clog in hose from impeller	Repair leaks; clear obstructions or replace hose.
	Impeller belt slipping due to grease on belt or looseness	Clean grease from belt or tighten. Re-size if too large.
	Impeller belt worn	Replace belt.
	Impeller failure	Check and repair.

PROBLEM	CAUSE	SOLUTION
Loss of dust control.	Debris in hose or impeller inlet	Clean.
	Broom skirts or seals worn	Replace.
	Skirt clearance from floor exceeds 1/8"	Adjust clearance.
	Dust filter clogged	Clean filters.
	Filter seal worn or missing	Replace.
	Impeller belt worn	Replace.
	Impeller belt slipping due to grease on belt or looseness	Clean or tighten.
	Poor seal with vacuum gasket at hopper	Visually check and adjust, if necessary.
Sweeper unit leaving debris.	Hopper full	Dump hopper.
	Broom(s) out of adjustment	Adjust.
	Broom bristles worn	Check broom for wear and adjustment.
	Poor performance of broom drive mechanism	Check for jam in broom chamber.
	Broom lift arms hung up with debris	Clear out debris.
	Hopper flaps damaged or missing	Replace or adjust clearance.
	Hopper out of adjustment	Check hopper floor clearance.
	Filters clogged	Clean filters.
Hopper does not raise or lower.	Hydraulics system problem:	See Hydraulics System Problems in this section.
	<ul style="list-style-type: none"> - control valve - gear pump - lift cylinder - relief valve 	
	Hopper arms binding	Lubricate or adjust arm linkage.

PROBLEM	CAUSE	SOLUTION
Hopper does not rotate or rotates slowly.	Hopper load too heavy Hydraulics system problem: - control valve - gear pump - lift cylinder - relief valve	Dump more frequently. See Hydraulics System Problems in this section.

HYDRAULIC SYSTEM PROBLEMS

Hopper lift cylinder failure.	Line to cylinder leaking Piston seals leaking Bent piston rod	Tighten fittings or replace hose. Replace seals. Replace rod.
Hydraulic control valve failure.	Misaligned control linkage Foreign matter in spool bore Valve seals leaking O-rings leaking Relief valve stuck open	Align. Remove spool and clean bore. Replace seals. Replace O-rings. Clean or replace relief valve.
Hydraulic motor failure.	Motor leaking Drive link malfunction Gerotor worn Output shaft malfunction	Replace seals. Replace drive link. Replace gerotor set. Replace output shaft and bearings.

PROBLEM	CAUSE	SOLUTION
Hydraulic gear pump failure.	Pump leaking	Replace seals
	Gears worn or scored	Rebuild pump.
	Relief valve stuck	Clean or replace (at control valve).
	Oil supply low	Check and fill.
	Oil strainer clogged	Replace strainer (inside reservoir).
	Incorrect oil	Use recommended viscosity oil.
	Damage due to entry of air into hydraulic system	Maintain correct hydraulic oil level in reservoir. Keep suction hose fittings tight.
Hydraulic variable displacement pump failure	Pump leaking	Replace seals.
	Relief valve(s) stuck	Clean or replace relief valve(s).
	Drive coupling malfunction	Replace coupling.
	Control linkage out of adjustment	Check to see if linkage is binding or unfastened.
	Charge pump gears worn or scored	Replace defective gears.
	Damage due to entry of air into hydraulic system	Maintain correct hydraulic oil level in reservoir. Keep suction hose fittings tight.
Hydraulic system noisy.	Air in system	Check oil level in reservoir; check for loose connections or leaks
	Relief valve dirty or damaged.	Clean or replace.
	Loose suction line	Tighten fittings.
	Clogged section filter or pump inlet line.	Replace filter, clear line; change oil in reservoir if dirty and flush system.
	Internal pump or motor damage	Inspect and repair.